

8750A STORAGE-NORMALIZER

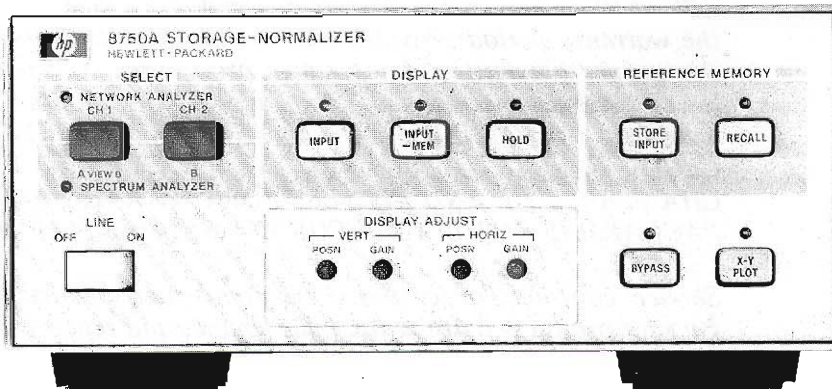

HEWLETT  PACKARD

HEWLETT  PACKARD

OPERATING AND SERVICE MANUAL

8750A STORAGE-NORMALIZER

SERIAL NUMBERS

This manual applies directly to HP Model 8750A Storage-Normalizers having serial number prefix 1712A.

For additional information about serial numbers refer to INSTRUMENTS COVERED BY MANUAL in Section I.

© Copyright HEWLETT-PACKARD COMPANY 1977
1400 FOUNTAIN GROVE PARKWAY, SANTA ROSA, CA. 95404 U.S.A.

MANUAL PART NO. 08750-90001
Operating Information Supplement Part No. 08750-90004

Printed: MAY 1977

CONTENTS

Section	Page	Section	Page
I GENERAL INFORMATION	1-1	4-4. X-Y Recorder Output Test	4-1
1-1. Introduction	1-1	4-5. Sweep Speed Test	4-3
1-4. Specifications	1-1	4-6. Performance Test with 8558B Spectrum Analyzer	4-4
1-6. Safety Considerations	1-3	4-7. X-Y Recorder Output Test	4-4
1-7. Safety Symbols	1-3	4-8. Sweep Speed Test	4-5
1-8. Operation	1-3	V ADJUSTMENTS	5-1
1-9. Service	1-3	5-1. Introduction	5-1
1-15. Instruments Covered by Manual	1-4	5-4. Equipment Required	5-1
1-20. Description	1-4	5-6. Adjustments and Test Points Locations	5-1
1-24. Option 001 BNC Interface Adapter	1-4	5-8. Cover Removal	5-1
1-26. Recommended Test Equipment	1-5	5-10. Sweep Input Gain and Offset	5-3
II INSTALLATION	2-1	5-11. Step Size	5-3
2-1. Introduction	2-1	5-12. Triangle Offset	5-4
2-3. Initial Inspection	2-1	5-13. Y Balance	5-4
2-5. Preparation for Use	2-1	5-14. Y Gain	5-5
2-6. Power Requirements	2-1	5-15. X Ramp	5-5
2-8. Line Voltage and Fuse Selection	2-1	VI REPLACEABLE PARTS	6-1
2-10. Cable Connections	2-1	6-1. Introduction	6-1
2-14. Environmental Considerations	2-2	6-3. Abbreviations	6-1
2-16. Packaging	2-4	6-5. Replaceable Parts List	6-1
2-17. Original Packaging	2-4	6-7. Ordering Information	6-1
2-19. Other Packaging	2-4	VII MANUAL CHANGES	7-1
III OPERATION	3-1	7-1. Introduction	7-1
3-1. Introduction	3-1	VIII SERVICE	8-1
3-3. Adjustments to Match 8750A to Network Analyzer	3-5	8-1. Introduction	8-1
3-5. Functional Test of Main Features with Network Analyzer	3-9	8-3. Safety	8-1
3-7. Adjustments to Match 8750A to Spectrum Analyzer	3-11	8-6. Overall Principles of Operation	8-1
3-9. Functional Test of Main Features with Spectrum Analyzer	3-14	8-8. Vertical Analog Input Signal	8-1
IV PERFORMANCE TESTS	4-1	8-10. Vertical Digital Signal	8-1
4-1. Introduction	4-1	8-12. Vertical Analog Output Signal	8-2
4-3. Performance Test with 8755B Network Analyzer	4-1	8-14. Horizontal Analog Input Signal	8-2
		8-16. Horizontal Digital Signal	8-2
		8-20. Horizontal Analog Output Signal	8-2

TABLES

Table	Page	Table	Page
1-1. Model 8750A Storage-Normalizer Specification	1-1	5-1. Adjustment Controls and Test Points	5-2
1-2. Model 8750A Supplemental Performance Characteristics	1-2	6-1. Reference Designations and Abbreviations	6-2
1-3. HP Instruments Compatible with 8750A	1-5	6-2. Replaceable Parts	6-4
1-4. Recommended Test Equipment	1-6	6-3. Code List of Manufacturers	6-11

ILLUSTRATIONS

Figure	Page	Figure	Page
1-1. Model 8750A Storage-Normalizer and Interconnect Cable	1-2	8-2. A1 Front Panel Board Assembly Block Diagram	8-4
1-2. Typical Serial Number Plate	1-4	8-3. A1 Front Panel Board Assembly Components Locations.	8-5
2-1. AC Power Level Selector Switch Positions	2-2	8-4. A1 Front Panel Board Assembly Schematic Diagram	8-5
2-2. AC Power Cables Available	2-3	8-5. A2 Analog Board Assembly Analog-to-Digital Circuits Block Diagram.	8-6
3-1. 8750A Front-Panel Controls and Indicators	3-1	8-6. A2 Analog Board Assembly Components Locations.	8-7
3-2. 8750A Rear-Panel Controls and Connectors.	3-4	8-7. A2 Analog Board Assembly Analog-to-Digital Circuits Schematic Diagram	8-7
3-3. Typical Test Setup with Model 8755B Network Analyzer	3-5	8-8. A2 Analog Board Assembly Line Generator Circuits Block Diagram.	8-8
3-4. Typical Test Setup with Model 8410A/B Network Analyzer	3-6	8-9. A2 Analog Board Assembly Line Generator Circuits Schematic Diagram	8-9
3-5. Typical Test Setup with Model 8407A Network Analyzer	3-6	8-10. A3 Digital Board Assembly Data Control Circuits Block Diagram.	8-10
3-6. 8750A Network Analyzer Interface Board	3-7	8-11. A3 Digital Board Assembly Components Locations.	8-11
3-7. Horizontal Display Adjustment	3-8	8-12. A3 Digital Board Assembly Data Control Circuits Schematic Diagram	8-11
3-8. Vertical Display Adjustment	3-9	8-13. A3 Digital Board Assembly Memory/Subtractor Circuits Block Diagram	8-12
3-9. Typical Test Setup with Spectrum Analyzer	3-11	8-14. A3 Digital Board Assembly Memory/Subtractor Circuits Schematic Diagram	8-13
3-10. 8750A Spectrum Analyzer Interface Board	3-12	8-15. A4 Motherboard Assembly Components Locations.	8-14
3-11. Spectrum Analyzer Calibration Signal used to Adjust 8750A.	3-13	8-16. A4 Motherboard Assembly Schematic Diagram	8-15
3-12. CRT Trace Showing Front-Panel VERT POSN Control Correctly Adjusted	3-14	8-17. A5 Network Analyzer Interface Board Assembly Components Locations.	8-17
3-13. CRT Trace Showing Front-Panel VERT GAIN Correctly Adjusted	3-15	8-18. A5 Network Analyzer Interface Board Assembly Schematic Diagram	8-17
4-1. Typical Test Setup for 8750A Performance Tests Using a Network Analyzer.	4-2	8-19. A5 Spectrum Analyzer Interface Board Assembly Components Locations.	8-19
4-2. Typical Test Setup for 8750A Performance Tests Using a Spectrum Analyzer	4-5	8-20. A5 Spectrum Analyzer Interface Board Assembly Schematic Diagram	8-19
5-1. Sweep Input Waveform at A2TP3.	5-3	8-21. 8750A AC Power Distribution Wiring Diagram	8-21
5-2. Stairstep Waveform at A2TP6	5-3		
5-3. Triangle Wave Generator Waveform at A2TP4 Showing Correct Offset	5-4		
5-4. Y-Generator Waveform at A2TP5. Expanded to show Correct Balance and Compensation.	5-4		
5-5. Y-Generator Waveform at A2TP5	5-5		
5-6. X Ramp Waveform showing Slow 0 to +1 Vdc Excursion of Trace	5-6		
5-7. Location of Adjustments	5-7		
8-1. Model 8750A Storage-Normalizer Overall Block Diagram	8-3		

MODEL 8750A



**NORMALIZER INTERCONNECT CABLE
HP 08750-60008**

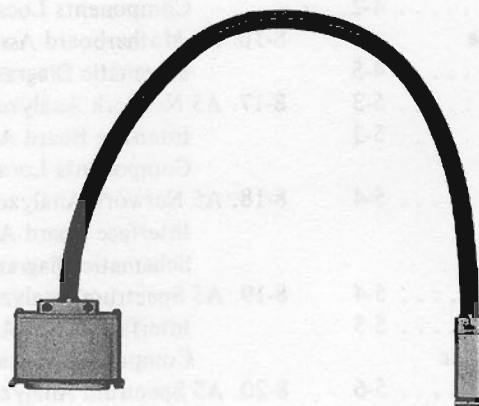

Figure 1-1. Model 8750A Storage-Normalizer and Interconnect Cable

SECTION I GENERAL INFORMATION

1-1. INTRODUCTION

1-2. This Operating and Service Manual contains information needed for installing, operating, testing, adjusting, and repairing the HP Model 8750A Storage-Normalizer, shown with its accessories in Figure 1-1. This section of the manual describes the 8750A and its accessories, and lists the instrument's specifications.

1-3. Supplied with this manual is an Operating Information Supplement. The Supplement is a copy of the first three sections of the manual, and should be kept with the instrument for use by the

operator. Additional copies of the Operation Information Supplement can be ordered separately through your nearest Hewlett-Packard office. The part number is listed on the title page.

1-4. SPECIFICATIONS

1-5. Instrument specifications are listed in Table 1-1. These specifications are the performance standards or limits against which the instrument is tested. Table 1-2 lists supplemental characteristics. Supplemental characteristics are not specifications, but are included as additional information for the user.

Table 1-1. Model 8750A Storage-Normalizer Specifications

Memory Resolution	X-Y Recorder Outputs
Horizontal: Two display memories, 256 data points per memory (0.4% of full scale, 8-bit word)	Horizontal: Range: 0V to 1V nominal
Vertical: 9-bit display resolution (0.2% of full scale (8-bit word) plus a 50% overrange both above and below full screen. The overrange capability is useful in storing and normalizing traces that exceed full scale.	Accuracy: 0V is within 20 mV of zero reference. Full scale is within ±3% of full scale reference.
Input Sweep Rate: Horizontal: Maximum: 100 seconds Minimum: 10 milliseconds	Vertical: Range: ±4V ±3% Accuracy: Full scale is within ±3% of full scale reference.

Table 1-2. Model 8750A Supplemental Performance Characteristics

Display Refresh Rate:

6 ms nominal

Video Detection:**Network Analyzer:**

Average detection (20 kHz)

Spectrum Analyzer:

Peak detection

Analog/Digital Inputs:**Horizontal Input****Network Analyzer:**

0 to 10V nominal

Offset $\pm 0.5V$

Gain adjustable for 6 to 15V sweep ramp

Spectrum Analyzer: $\pm 5V$ nominalOffset $\pm 0.5V$ Gain adjustable $\pm 4.5V$ to $\pm 5.5V$ **Vertical Input:****Network Analyzer:**

Two ranges: +1V to -1V; and +2V to -2V

Offset $\pm 0.3V$ Gain adjustable approximately $\pm 20\%$ **Spectrum Analyzer:**

0 to +0.8V or 0 to -0.8V

Offset $\pm 0.1V$ Gain adjustable $\pm 10\%$ **Digital/Analog Output:****Horizontal Output:****Network Analyzer:**

Gain adjustable from 1 to 3V peak

Offset adjustment allows $\pm 1.5V$ or 0 to 3V

sweep output

Spectrum Analyzer:

0 to 3V nominal

Offset $\pm 0.5V$

Gain adjustable from 0.7V to 3.5V

Digital/Analog Output:**Vertical Output:****Network Analyzer:**Same as vertical input with $\pm 10\%$ adjustment range**Spectrum Analyzer:**Same as vertical input with $\pm 10\%$ adjustment range**X-Y Recorder Outputs:****Sweep Time:**

30 seconds per displayed trace

Pen Lift:

0V minimum, 20V maximum. Maximum sink (pen down) current is 150 mA.

Interface:**Blanking In:**

Blanked = High (typically 3.5V into 20K ohms impedance)

Unblanked = Low (typically 0.5V)

Blanking Out:

Blanked = High (typically 3.5V at 4 mA max.)

Unblanked = Low (typically 0.4V at 10 mA max.)

or

Blanked = Low (typically 0.4V at 10 mA max.)

Unblanked = High (typically 3.5V at 4 mA max.)

Power Requirements:

100, 120, 220, or 240 Vac +5% - 10%;

48 to 440 Hz; ≤ 20 VA (≤ 20 watts)**Dimensions:**

212 mm wide, 88 mm high, 269 mm deep

(8.4 in. x 3.5 in. x 10.6 in.)

Weight:

2.72 kg (6 lbs) net;

4.99 kg (11 lbs) shipping

1-6. SAFETY CONSIDERATIONS

1-7. Safety Symbols



Instruction manual symbol: the apparatus will be marked with this symbol when it is necessary for the user to refer to the instruction manual in order to protect the apparatus against damage.



Indicates dangerous voltages.



Earth terminal (sometimes used in manual to indicate circuit connected to grounded chassis).

WARNING

The WARNING sign denotes a hazard. It calls attention to a procedure, practice, or the like, which, if not correctly performed or adhered to, could result in injury or loss of life. Do not proceed beyond a WARNING sign until the indicated conditions are fully understood and met.

CAUTION

The CAUTION sign denotes a hazard. It calls attention to an operating procedure, practice, or the like, which, if not correctly performed or adhered to, could result in damage to or destruction of part or all of the equipment. Do not proceed beyond a CAUTION sign until the indicated conditions are fully understood and met.

1-8. Operation

CAUTION

BEFORE APPLYING POWER make sure the instrument's ac input is set for the available ac line voltage, that the correct fuse is installed, and that all normal safety precautions have been taken.

1-9. Service

1-10. The information, cautions, and warnings

in this manual must be followed to ensure safe operation. **SDERVICE AND ADJUSTMENTS SHOULD BE PERFORMED ONLY BY QUALIFIED SERVICE PERSONNEL.**

1-11. Adjustment or repair of the opened instrument with the ac power connected should be avoided as much as possible and, when unavoidable, should be performed only by a skilled person who knows the hazard involved.

1-12. Capacitors inside the instrument may still be charged even though the instrument has been disconnected from its source of supply.

1-13. Make sure only fuses of the required current rating and type (normal blow, time delay, etc.) are used for replacement. Fuse requirements are indicated on the instrument's rear panel. Do not use repaired fuses or short-circuit fuse holders.

1-14. Whenever it is likely that the earth ground protection has been interrupted, make the instrument inoperative and secure it against any unintended operation.

WARNING

If this instrument is to be energized through an auto-transformer (for voltage reduction), make sure the common terminal is connected to the earthed pole of the power source.

BEFORE SWITCHING ON THE INSTRUMENT, the protective earth terminal of the instrument must be connected to the protective conductor of the (mains) power cord. The mains plug shall only be inserted in a socket outlet provided with protective earth contact. The protection must not be negated by using an extension cord (power cable) without a protective grounding conductor. Grounding one conductor of a two-conductor outlet is not sufficient protection.

Any interruption of the protective (grounding) conductor, inside or

outside the instrument, or disconnection of the protective earth terminal is likely to make this instrument dangerous. Intentional interruption of the earth ground is prohibited.

1-15. INSTRUMENTS COVERED BY MANUAL

1-16. Attached to the instrument is a serial number plate (Figure 1-2). The serial number is in two parts. The first four digits and the letter are the serial number prefix; the last five digits are the suffix. The prefix is the same for all identical instruments; it changes only when a change is made to the instrument. The suffix, however, is assigned sequentially and is different for each instrument. The contents of this manual apply to instruments with the serial number prefix(es) listed under SERIAL NUMBERS on the title page.

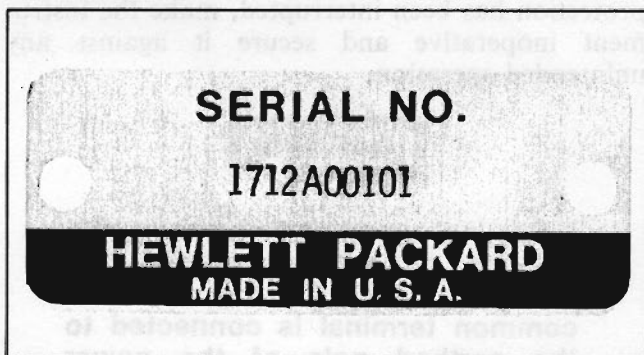

Figure 1-2. Typical Serial Number Plate

1-17. An instrument manufactured after the printing of this manual may have a serial number prefix that is not listed on the title page. This unlisted serial number prefix indicates the instrument is different from those described in this manual. The manual for this newer instrument is accompanied by a yellow Manual Changes supplement. This supplement contains "change information" that explains how to adapt the manual to the newer instrument.

1-18. In addition to change information, the supplement contains instructions for correcting any errors in the manual. To keep this manual as current as possible, Hewlett-Packard recommends that you periodically request the latest Manual Changes supplement. The supplement for this manual is identified with this manual's print date

and part number, both of which appear on the manual's title page. Complimentary copies of the supplement are available from Hewlett-Packard.

1-19. For information concerning a serial number prefix that is not listed on the title page or in the Manual Changes supplement, contact your nearest Hewlett-Packard office.

1-20. DESCRIPTION

1-21. The Model 8750A Storage-Normalizer is used with various Hewlett-Packard network and spectrum analyzers (see Table 1-3) to furnish digitally-stored and normalized X and Y CRT displays. In network analyzer applications, the 8750A provides two channels, each with 256 points of horizontal resolution, for simultaneous displays of insertion loss and return loss, magnitude and phase, etc.

1-22. Used with a spectrum analyzer, the 8750A enables a stored trace and an occurring trace, or two stored traces, to be displayed simultaneously on the spectrum analyzer CRT. The normalized trace can also be displayed.

1-23. Two interface board assemblies, which plug into the 8750A's rear panel, are provided. One interface board adapts the 8750A for use with network analyzers, and the other adapts it for use with spectrum analyzers. A storage bracket inside the 8750A holds the interface board not in use. Also supplied with the 8750A is a Direct Interface Cable, HP Part Number 08750-60008. This cable is 60 cm (23-5/8 inches) long and provides a direct connection between the 8750A and compatible HP oscilloscope mainframes, network analyzers, and spectrum analyzers.

1-24. OPTION 001 BNC INTERFACE ADAPTER

1-25. Option 001 deletes the Direct Interface Cable and substitutes the BNC Interface Adapter, HP Part Number 08750-60014. This adapter allows the 8750A and an oscilloscope to be used with HP 140 Series Spectrum Analyzers, providing both a conventional CRT display and a digitally-stored display.

Table 1-3. HP Instruments Compatible with 8750A

Instrument	Serial Number Prefixes of Compatible Instruments
Model 182T Oscilloscope Mainframe Model 180TR Oscilloscope Mainframe Model 8412A Oscilloscope Display Model 8505A Network Analyzer Model 8557A Spectrum Analyzer Plug-In Model 8558B Spectrum Analyzer Plug-In Model 8565A Spectrum Analyzer Model 8755A Frequency Response Test Set Model 8755B Frequency Response Test Set	1705A and up ¹ 1704A and up ² 1713A and up ³ All prefixes 1709A and up ⁴ 1707A and up ⁵ All prefixes All require retrofit ⁶ All prefixes
<p>¹ Earlier instruments retrofittable with Retrofit Kit HP 08750-60024.</p> <p>² Earlier instruments retrofittable with Retrofit Kit HP 08750-60025.</p> <p>³ Earlier instruments retrofittable at HP Service Center. Contact nearest Hewlett-Packard office for further information.</p> <p>⁴ Earlier instruments retrofittable with Retrofit Kit HP 08557-60060.</p> <p>⁵ Earlier instruments retrofittable with Retrofit Kit HP 08558-60092.</p> <p>⁶ All instruments retrofittable with Retrofit Kit HP 08755-60027.</p>	

1-26. RECOMMENDED TEST EQUIPMENT

1-27. Equipment required for incoming inspection, performance testing, and troubleshooting of

the Model 8750A Storage-Normalizer is listed in Table 1-4. Other equipment may be substituted for the listed equipment if it meets or exceeds the critical specifications given in the table.

* P = Performance Test; T = Troubleshooting; I = Incoming Inspection; A = Adjustment Procedure
 ** With this group of instruments, you can troubleshoot the 8750A without using a Network Analyzer or Spectrum Analyzer

Table I-4. Recommended Test Equipment

Instrument	Critical Specifications	Recommended Model	Use*
Normalizer Interconnect Cable	No substitute. Supplied with 8750A.	HP 08750-60008	P, A, T, I
Spectrum Analyzer or Network Analyzer System that will display a trace on CRT	No substitutes. 8750A is not compatible with systems other than the recommended ones.	HP 8557A/182T or 8558B/182T or 8410B/8412A/8620C/ RF Section/11666A or other comparable combination. NOTE: For troubleshooting only, see ** below.	P, A, T, I
X-Y Recorder	Sensitivity, X and Y: ≥ 10 mV/cm	HP 7015A	I
Digital Multimeter and Probe	DC Volts: 0 to 60V AC Volts: 0 to 300V Ohms: To 20 Megohms	HP 3465B/34112A	T
DC Power Supply **	DC Output: 0 to 10V	HP 6205B	T
Function Generator **	Output Waveform: 0 to 10V ramp or triangle	HP 3311A	T
Oscilloscope with ** Dual-Channel Plug-In	Freq Range: DC to 50 MHz	HP 180C/1805A/1825A	A, T
10:1 Probe (2 required) **	Division Ratio: 10:1 Shunt Cap. 10 pF	HP 10004D	A, T
Interconnect Cable ** (8750A Option 001)	No substitute	HP 08750-60014	T

* P = Performance Tests; T = Troubleshooting; I = Incoming Inspection; A = Adjustment Procedure.

** With this group of instruments, you can troubleshoot the 8750A without using a Network Analyzer or Spectrum Analyzer.

SECTION II INSTALLATION

2-1. INTRODUCTION

2-2. This section includes information on initial inspection, preparation for use, and storage and shipment of the HP Model 8750A Storage-Normalizer.

2-3. INITIAL INSPECTION

2-4. Inspect the shipping container for damage. If the shipping container or cushioning material is damaged, it should be kept until the contents of the shipment have been checked for completeness and the instrument has been checked mechanically and electrically. The contents of the shipment should be as shown in Figure 1-1. Procedures for checking electrical performance are given in Section IV. If the contents are incomplete, if there is mechanical damage or defect, or if the instrument does not pass the electrical performance test, notify the nearest Hewlett-Packard office. If the shipping container is damaged, or the cushioning material shows signs of stress, notify the carrier as well as the Hewlett-Packard office. Keep the shipping materials for carrier's inspection. The HP office will arrange for repair or replacement without waiting for claim settlement.

2-5. PREPARATION FOR USE

2-6. Power Requirements

2-7. The Model 8750A requires a power source of 100, 120, 220, or 240 Vac $\pm 5\%$ – 10% , 48 to 440 Hz single phase. Power consumption is less than 20 volt-amperes.

2-8. Line Voltage and Fuse Selection

WARNING

BEFORE THIS INSTRUMENT IS SWITCHED ON, its protective earth terminals must be connected to the protective conductor of the mains power cable (cord). The mains power cable plug shall only be inserted in a socket outlet provided with a pro-

ective earth contact. DO NOT negate the earth-grounding protection by using an extension cable, power cable, or autotransformer without a protective ground conductor. Failure to ground the instrument properly can result in serious personal injury.

CAUTION

BEFORE SWITCHING ON THIS INSTRUMENT, make sure it is adapted to the voltage of the ac power source. You must set the voltage selector switch correctly to adapt the 8750A to the power source. Failure to set the ac power input of the instrument for the correct voltage level could cause damage to the instrument when it is switched on.

2-9. Select the line voltage and fuse as follows:

- a. Measure the ac line voltage.
- b. Refer to Figure 2-1. At the instrument's rear panel ac power level switch, select the line voltage (100V, 120V, 220V, 240V) closest to the voltage you measured in step a. Line voltage must be within $+5\%$ or -10% of the voltage setting. If it is not, you must use an autotransformer between the ac source and the 8750A.
- c. Make sure the correct fuse is installed in the fuse holder. The required fuse rating for each line voltage selection is indicated next to the fuse holder (250 mA for 100/120V, 125 mA for 220/240V).

2-10. Cable Connections

2-11. **Power Cable.** In accordance with international safety standards, this instrument is equipped with a three-wire power cable. When connected to an appropriate power line outlet, this cable grounds the instrument cabinet. Figure 2-2 shows the styles of mains plugs available on power

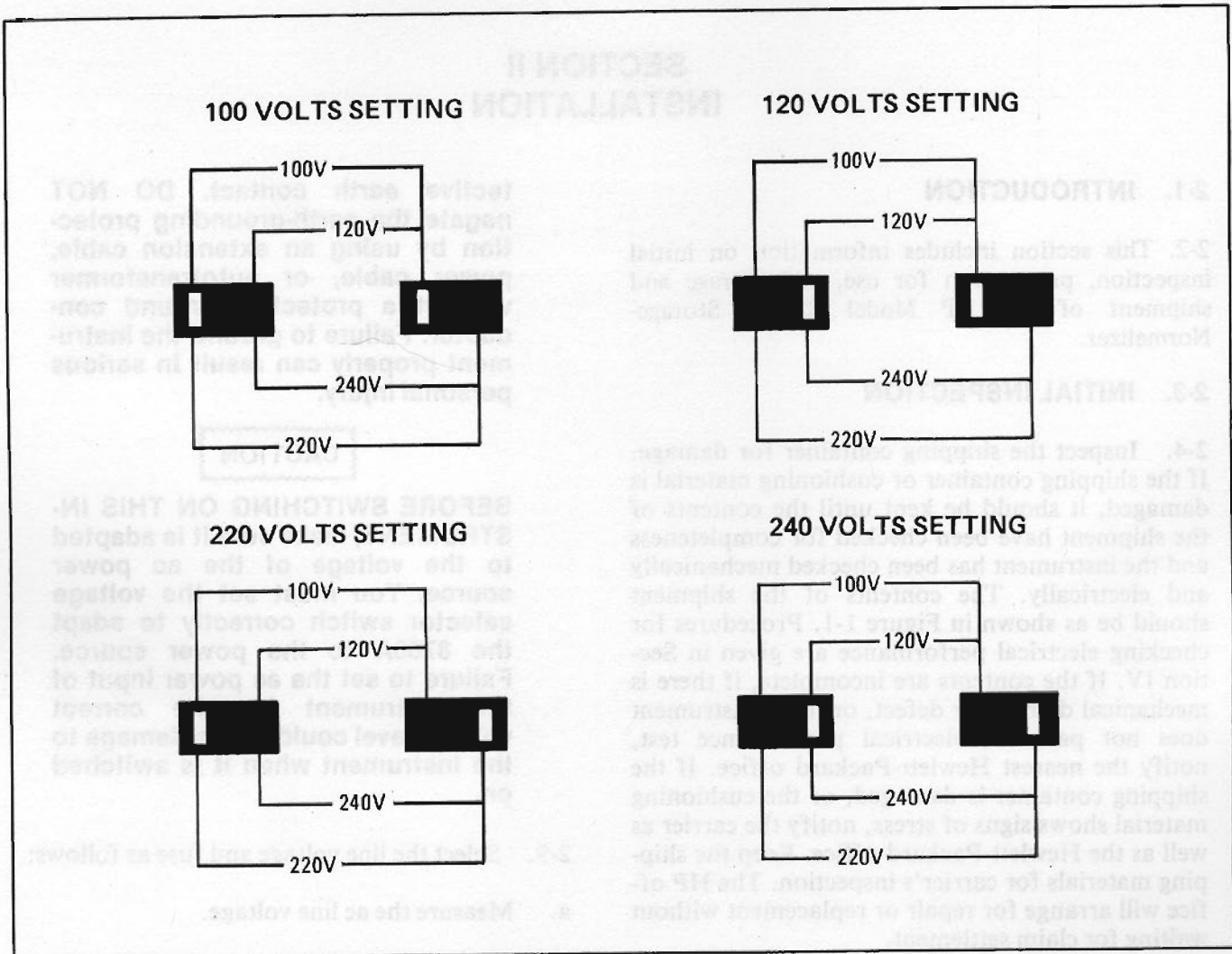

Figure 2-1. AC Power Level Selector Switch Positions

cables supplied with HP instruments. The HP part numbers shown with each plug are the part numbers for the complete power cable.

2-12. Connection to Network or Spectrum Analyzer. The 60 cm cable (HP Part No. 08750-60008) supplied with the 8750A connects directly between the 8750A and the display it is used with. (For a list of instruments that are compatible with the 8750A, see Table 1-3.) The two ends of this cable are identical. Connect one end to the NORMALIZER INTERCONNECT receptacle on the rear panel of the 8750A and the other end to the NORMALIZER INTERCONNECT receptacle on the rear of the network analyzer or spectrum analyzer display.

2-13. If your test setup includes an X-Y recorder, connect the recorder inputs to the RECORDER OUTPUT BNC connectors (X, Y, and PEN) on

the rear panel of the 8750A. For connections between the display and other test instruments, refer to the Operation Section (Section III) of this manual.

2-14. ENVIRONMENTAL CONSIDERATIONS

2-15. Environmental limitations for the 8750A are:

Temperature: 0°C to 55°C operating; -40°C to +75°C stored or in shipment.

Humidity: Up to 95% relative, whether operating, stored, or in shipment.

Altitude (Barometric): 4572 meters (15,000 feet) operating; 15240 meters (50,000 feet) stored or in shipment.





Plug Type	HP Part Number	Plug Description	Cable Length (inches)	Cable Color	For Use In Country
	8120-1351 8120-1703	Straight 90°	90 90	Mint Gray Mint Gray	Great Britain Cyprus, Nigeria Rhodesia Singapore So. Africa, India
	8120-1369 8120-0696	Straight 90°	79 87	Gray Gray	Australia New Zealand
	8120-1689 8120-1692	Straight 90°	79 79	Mint Gray Mint Gray	East and West Europe, Saudi Arabia, United Arab Republic (unpolarized in many nations)
	8120-1348 8120-1398 8120-1754	Straight 90° Straight	80 80 36	Black Black Black	United States Canada Japan (100 or 200V) Mexico Phillippines Taiwan
	8120-1378 8120-1521 8120-1676	Straight 90° Straight	80 80 36	Jade Gray Jade Gray Jade Gray	
	8120-2104	Straight	79	Gray	Switzerland

Figure 2-2. AC Power Cables Available

2-16. PACKAGING

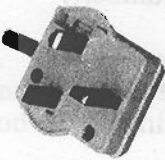
2-17. Original Packaging

2-18. Containers and materials identical with those used in factory packaging are available through Hewlett-Packard offices. If the instrument is being returned to Hewlett-Packard for servicing, attach a tag indicating the type of service required, return address, model number, and full serial number. Also, mark the container **FRAGILE** to ensure careful handling. In any correspondence, refer to the instrument by model number and full serial number.

2-19. Other Packaging

2-20. The following general instructions apply for repackaging with commercially available materials.

- a. Wrap the instrument in heavy paper or plastic. (If shipping to a Hewlett-Packard office or service center, attach a tag indicating the type of service required, return address, model number, and full serial number.)
- b. Use a strong shipping container. A double-wall carton made of 275 pound bursting strength corrugated single-wall box is sufficient.
- c. Use enough shock-absorbing material (3-to-4-inch layer) around all sides of the instrument to provide a firm cushion and prevent movement inside the container. Protect the control panel with cardboard.
- d. Seal the shipping container.
- e. Mark the shipping container **FRAGILE** to ensure careful handling.

United States	Black	10	10	10	10
Canada	Black	10	10	10	10
Japan (100 or 200V)	Black	10	10	10	10
Mexico	Light Gray	10	10	10	10
Philippines	Light Gray	10	10	10	10
Taiwan	Light Gray	10	10	10	10
Switzerland	Gray	10	10	10	10

Figure 2-2. AC Power Cables Available

SECTION III OPERATION

3-1. INTRODUCTION

3-2. This section explains the functions of the 8750A Storage-Normalizer's controls, indicators, and connectors. Procedures in this section describe

how to adjust the 8750A to adapt it to a network analyzer (Paragraph 3-3) or a spectrum analyzer (Paragraph 3-7). It also contains a functional test of the instrument, which may be used for incoming inspection or for an operators check of the 8750A's major modes of operation.

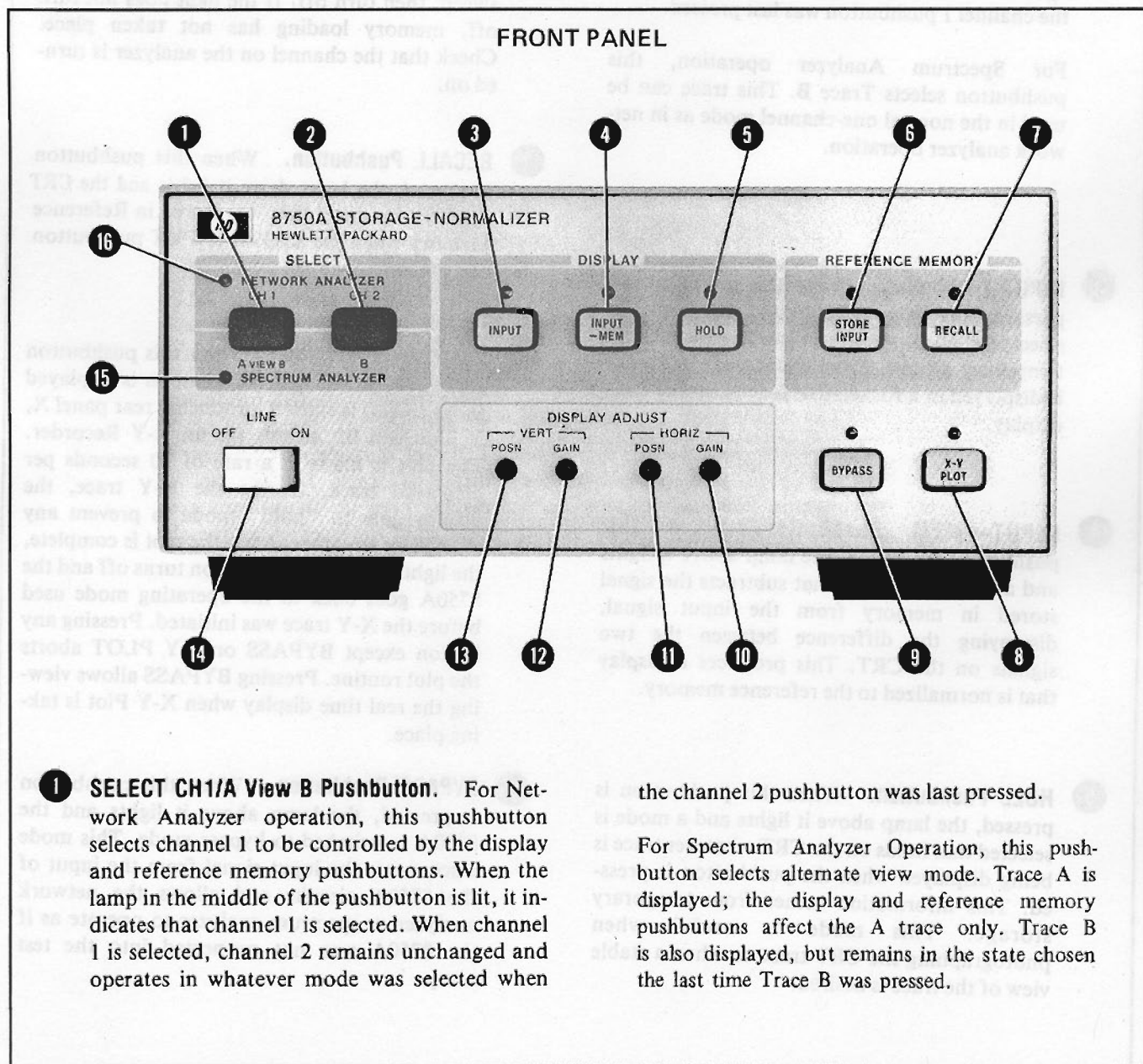

Figure 3-1. 8750A Front-Panel Controls and Indicators (1 of 3)

FRONT PANEL

2 SELECT CH 2/B Pushbutton. For Network Analyzer operation, this pushbutton selects channel 2 to be controlled by the display and reference memory pushbuttons. When the lamp in the middle of the pushbutton is lit, it indicates that channel 2 is selected. When channel 2 is selected, channel 1 remains unchanged and operates in whatever mode was selected when the channel 1 pushbutton was last pressed.

For Spectrum Analyzer operation, this pushbutton selects Trace B. This trace can be used in the normal one-channel mode as in network analyzer operation.

3 INPUT Pushbutton. When this pushbutton is pressed, the lamp above it lights and the selected channel signal is allowed to enter into temporary storage. From this storage, the trace is displayed in a flicker-free format on the CRT display.

4 INPUT—MEM Pushbutton. When this pushbutton is pressed, the lamp above it lights and a mode is selected that subtracts the signal stored in memory from the input signal, displaying the difference between the two signals on the CRT. This produces a display that is normalized to the reference memory.

5 HOLD Pushbutton. When this pushbutton is pressed, the lamp above it lights and a mode is selected that holds on the CRT whatever trace is being displayed when the pushbutton is pressed. This information comes from temporary storage. This mode is useful when photographing the CRT trace or when a stable view of the trace is desired.

6 STORE INPUT Pushbutton. Pressing this pushbutton causes the signal at the input to be stored in Reference Memory. The signal stored in this memory may be accessed by the RECALL button or, when operating in normalized mode, by pressing the INPUT—MEM pushbutton. When this pushbutton is pressed, the lamp above it should light for one input sweep, then turn off. If the light does not turn off, memory loading has not taken place. Check that the channel on the analyzer is turned on.

7 RECALL Pushbutton. When this pushbutton is pressed, the lamp above it lights and the CRT displays the signal that was stored in Reference Memory when the STORE INPUT pushbutton was pressed.

8 X-Y PLOT Pushbutton. When this pushbutton is pressed, an X-Y plot of whatever is displayed (both traces) is started, producing rear panel X, Y, and pen lift signals for an X-Y Recorder. The plot is made at a rate of 30 seconds per displayed trace. During the X-Y trace, the display goes to "hold" mode to prevent any change of the trace. After the plot is complete, the light above the pushbutton turns off and the 8750A goes back to the operating mode used before the X-Y trace was initiated. Pressing any button except BYPASS or X-Y PLOT aborts the plot routine. Pressing BYPASS allows viewing the real time display when X-Y Plot is taking place.

9 BYPASS Pushbutton. When this pushbutton is pressed, the lamp above it lights and the 8750A is switched to bypass mode. This mode disconnects the input signal from the input of the 8750A circuits and allows the network analyzer or spectrum analyzer to operate as if the 8750A was not connected into the test setup.

Figure 3-1. 8750A Front-Panel Controls and Indicators (2 of 3)

FRONT PANEL

- 10 HORIZ GAIN (Horizontal Gain) Control.** This control adjusts the gain of the 8750A Horizontal Output Amplifier. It works in conjunction with the HORIZ POSN (horizontal position) control to set the width and center the display trace horizontally on the CRT graticule. The ends of the trace should be adjusted to the edge graticule lines.
- 11 HORIZ POSN (Horizontal Position) Control.** This control works in conjunction with the HORIZ GAIN control to center the displayed trace between the edges of the CRT graticule.
- 12 VERT GAIN (Vertical Gain) Control.** This control adjusts the gain of the 8750A Vertical Output Amplifier. It works in conjunction with the VERT POSN control to set the top and bottom cutoff point of the displayed trace. The trace is normally set to cut off about 1/8 inch below the bottom graticule line and above the top graticule line.
- 13 VERT POSN (Vertical Position) Control.** This control is used to center the display area. If the input signal = signal in memory, then input - memory equals the center line of the display. To set this control, the input signal is placed in reference memory, the INPUT—MEM is selected. The control is then adjusted to place the trace on the center line of the display.
- 14 LINE OFF/ON Switch.** This switch controls the power to the 8750A.
- 15 SPECTRUM ANALYZER Lamp.** This lamp lights when the Spectrum Analyzer interface board is plugged into the rear panel of the 8750A.
- 16 NETWORK ANALYZER Lamp.** This lamp lights when the Network Analyzer interface board is plugged into the rear panel of the 8750A.

Figure 3-1. 8750A Front-Panel Controls and Indicators (3 of 3)

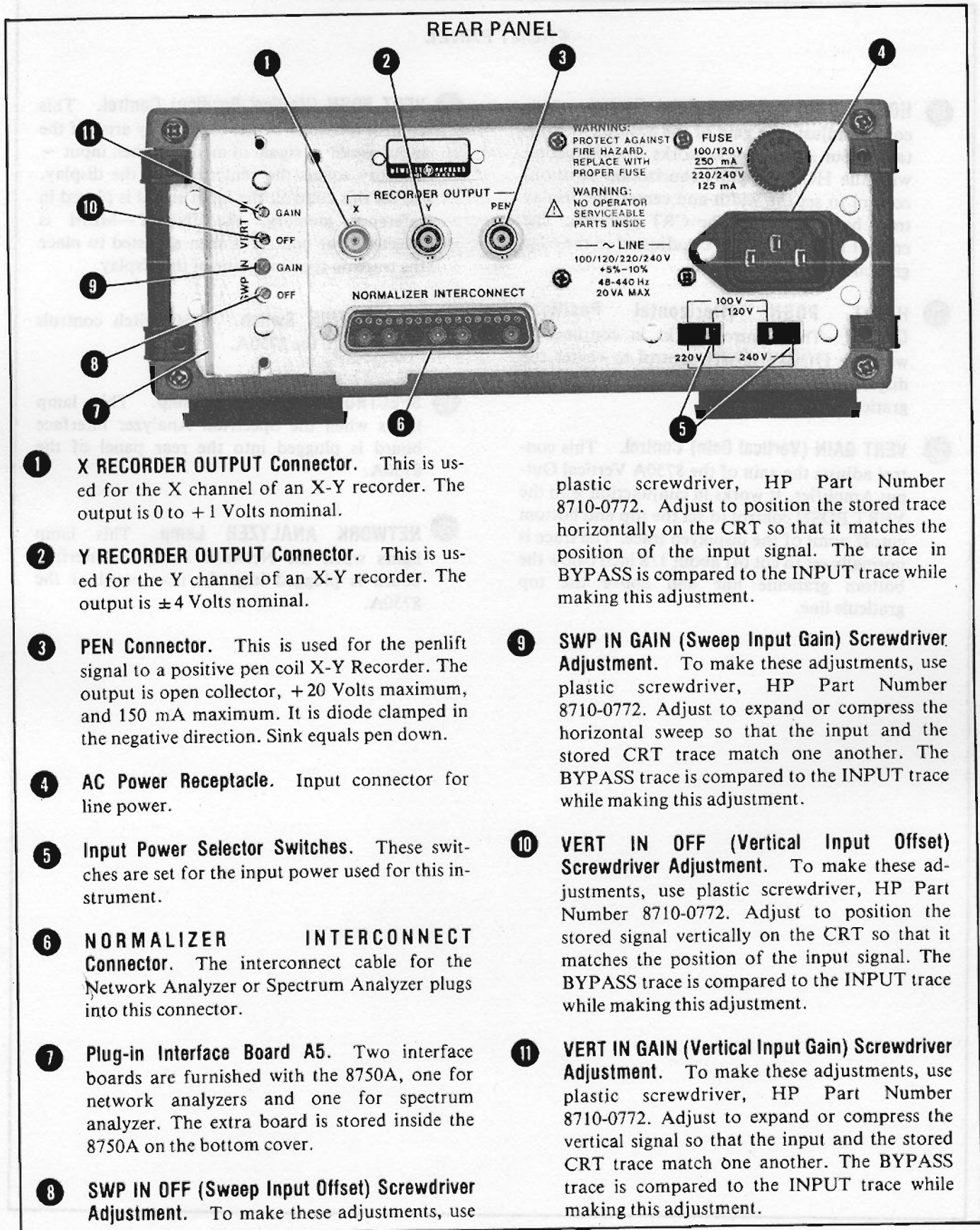

- 1 X RECORDER OUTPUT Connector.** This is used for the X channel of an X-Y recorder. The output is 0 to +1 Volts nominal.
- 2 Y RECORDER OUTPUT Connector.** This is used for the Y channel of an X-Y recorder. The output is ± 4 Volts nominal.
- 3 PEN Connector.** This is used for the penlift signal to a positive pen coil X-Y Recorder. The output is open collector, +20 Volts maximum, and 150 mA maximum. It is diode clamped in the negative direction. Sink equals pen down.
- 4 AC Power Receptacle.** Input connector for line power.
- 5 Input Power Selector Switches.** These switches are set for the input power used for this instrument.
- 6 NORMALIZER INTERCONNECT Connector.** The interconnect cable for the Network Analyzer or Spectrum Analyzer plugs into this connector.
- 7 Plug-in Interface Board A5.** Two interface boards are furnished with the 8750A, one for network analyzers and one for spectrum analyzer. The extra board is stored inside the 8750A on the bottom cover.
- 8 SWP IN OFF (Sweep Input Offset) Screwdriver Adjustment.** To make these adjustments, use

- plastic screwdriver, HP Part Number 8710-0772. Adjust to position the stored trace horizontally on the CRT so that it matches the position of the input signal. The trace in BYPASS is compared to the INPUT trace while making this adjustment.
- 9 SWP IN GAIN (Sweep Input Gain) Screwdriver Adjustment.** To make these adjustments, use plastic screwdriver, HP Part Number 8710-0772. Adjust to expand or compress the horizontal sweep so that the input and the stored CRT trace match one another. The BYPASS trace is compared to the INPUT trace while making this adjustment.
- 10 VERT IN OFF (Vertical Input Offset) Screwdriver Adjustment.** To make these adjustments, use plastic screwdriver, HP Part Number 8710-0772. Adjust to position the stored signal vertically on the CRT so that it matches the position of the input signal. The BYPASS trace is compared to the INPUT trace while making this adjustment.
- 11 VERT IN GAIN (Vertical Input Gain) Screwdriver Adjustment.** To make these adjustments, use plastic screwdriver, HP Part Number 8710-0772. Adjust to expand or compress the vertical signal so that the input and the stored CRT trace match one another. The BYPASS trace is compared to the INPUT trace while making this adjustment.

Figure 3-2. 8750A Rear-Panel Controls and Connectors

3-3. ADJUSTMENTS TO MATCH 8750A TO NETWORK ANALYZER

3-4. Before the 8750A can be used with a network analyzer to make measurements, it must be matched to the measurement system as follows:

NOTE

The following procedure was written using the 8755B. If you are using some other Model Network Analyzer, the procedure is the same but the name of the controls may be different.

1. Connect equipment as shown in Figure 3-3, 3-4, or 3-5.

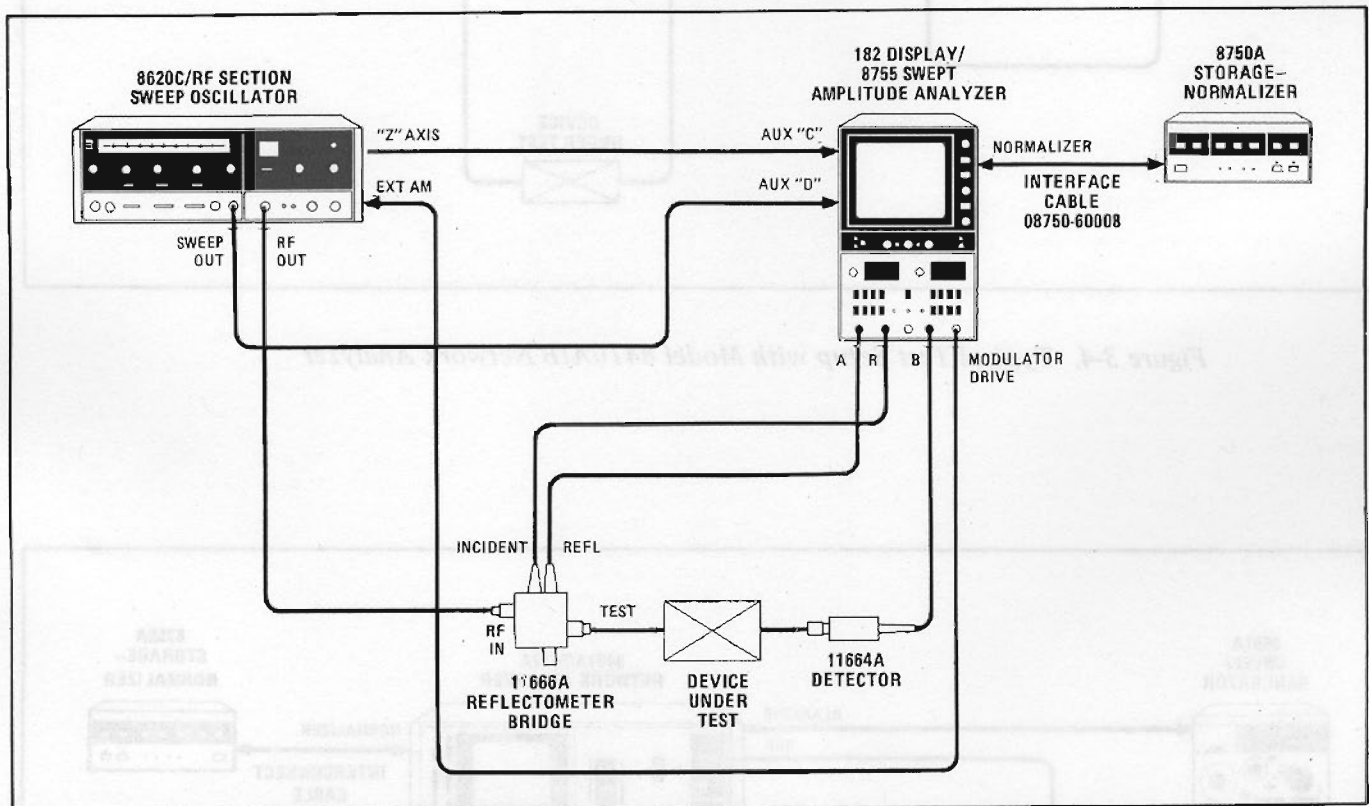

Figure 3-3. Typical Test Setup with Model 8755B Network Analyzer

2. On 8750A:
 - a. If installed, pull out A5 Network Analyzer Interface Board at rear panel of 8750A. (See Figure 3-6.)
 - b. Set the switches on A5 to one of the combinations shown in Figure 3-6, depending on what network analyzer is used.
 - c. Install A5 into the 8750A rear panel.
 - d. Press front-panel .

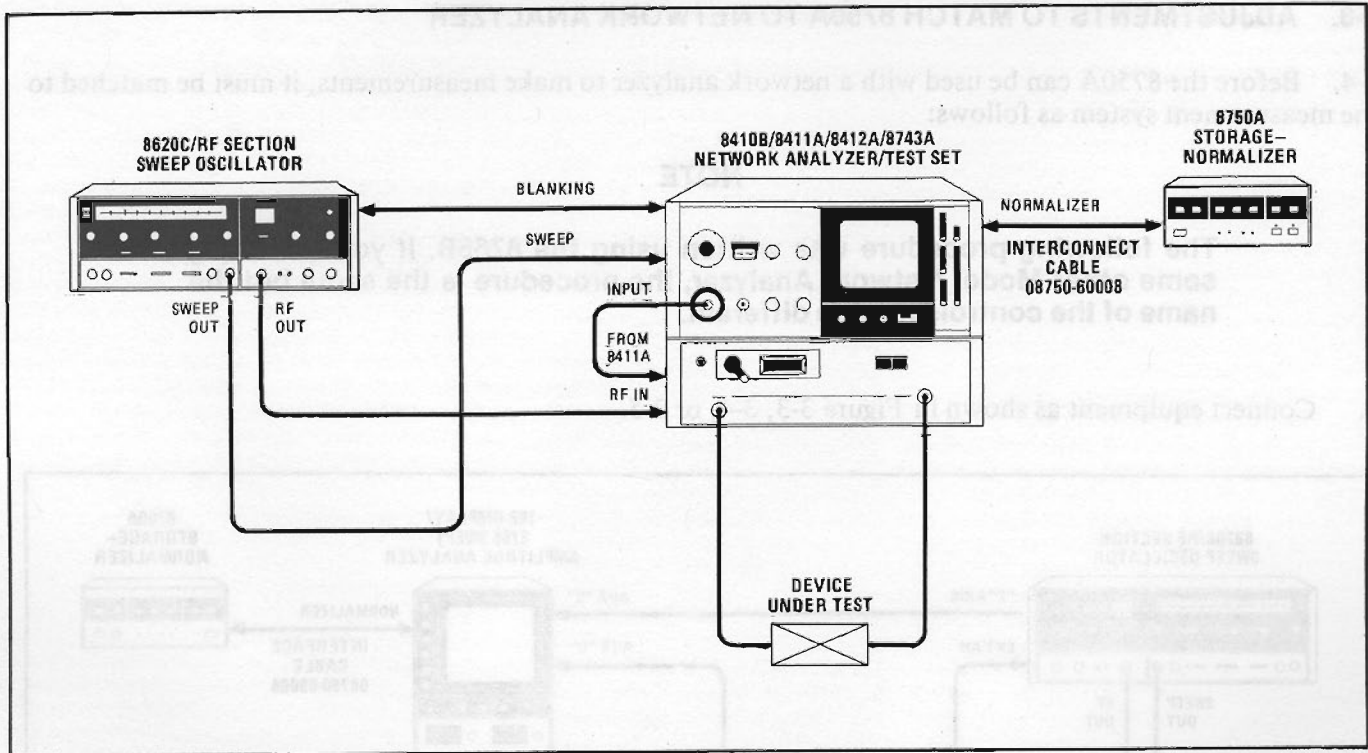

Figure 3-4. Typical Test Setup with Model 8410A/B Network Analyzer

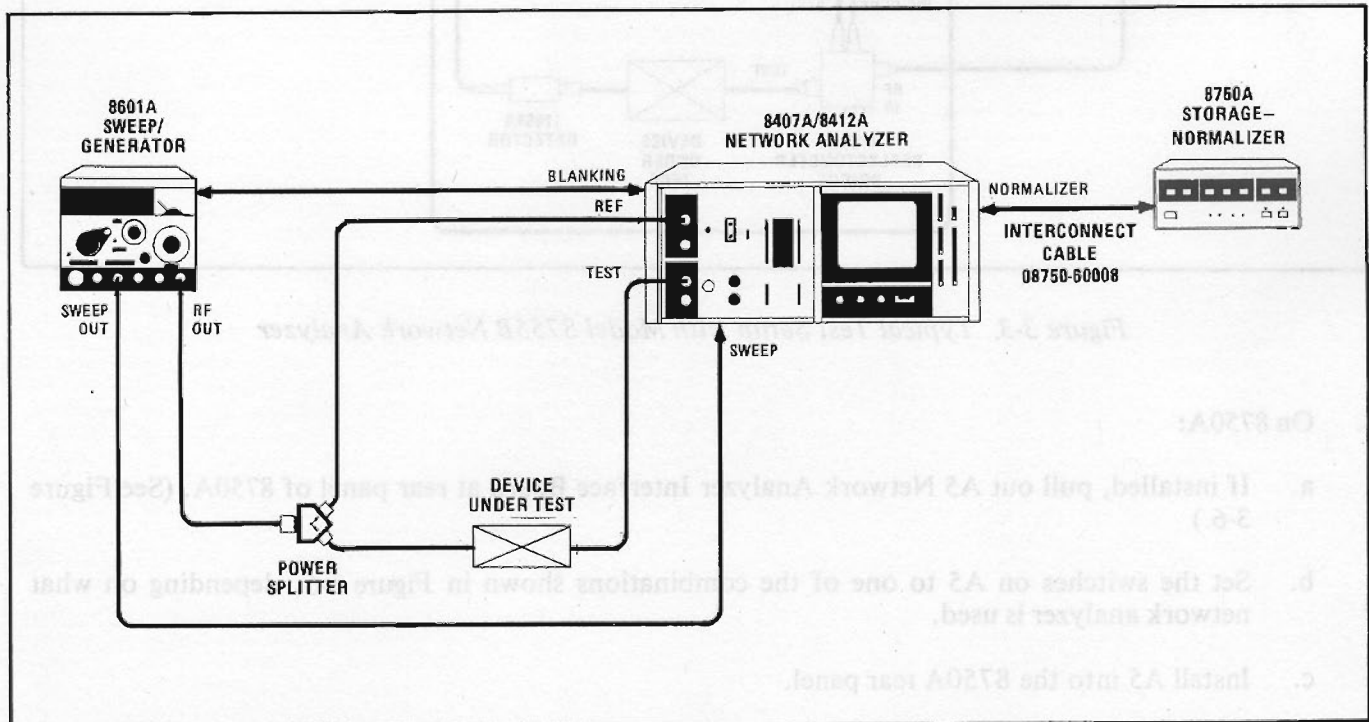

Figure 3-5. Typical Test Setup with Model 8407A Network Analyzer

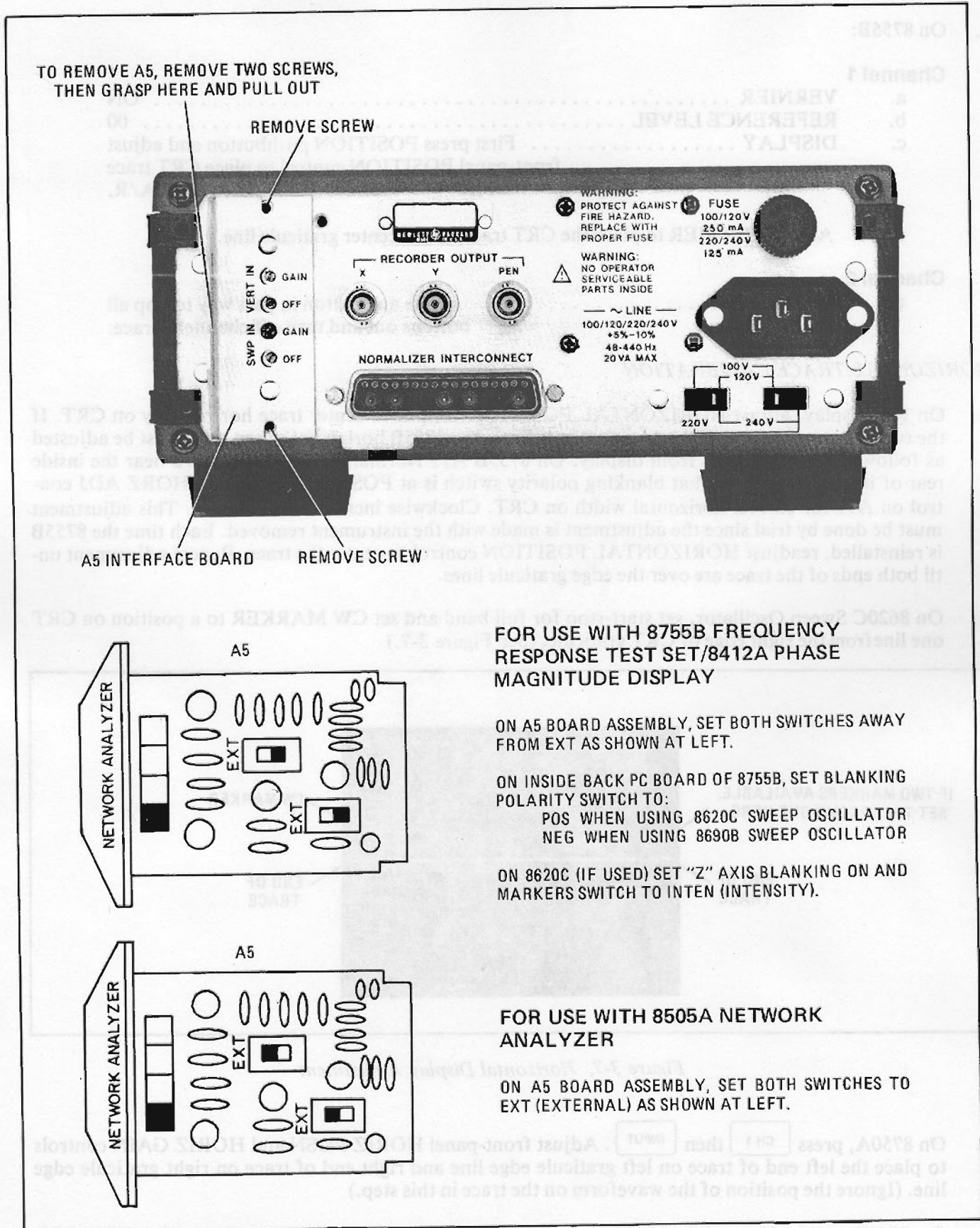

Figure 3-6. 8750A Network Analyzer Interface Board

3. On 8755B:

Channel 1

- a. VERNIER ON
- b. REFERENCE LEVEL 00
- c. DISPLAY First press POSITION pushbutton and adjust front-panel POSITION control to place CRT trace on center line, then press A/R.
- d. Adjust VERNIER to place the CRT trace on the center graticule line.

Channel 2

- a. DISPLAY Press any button in part way to pop all buttons out and turn off channel 2 trace.

HORIZONTAL TRACE CALIBRATION

- 4. On 182 Display, adjust HORIZONTAL POSITION control to center trace horizontally on CRT. If the two end dots are not on the edge graticule lines, the 8755B horizontal sweep gain must be adjusted as follows. Remove 8755B from display. On 8755B A11 Normalizer Interface board near the inside rear of instrument, check that blanking polarity switch is at POS position. Adjust HORZ ADJ control on A11 for correct horizontal width on CRT. Clockwise increases trace width. This adjustment must be done by trial since the adjustment is made with the instrument removed. Each time the 8755B is reinstalled, readjust HORIZONTAL POSITION control to center the trace. Repeat adjustment until both ends of the trace are over the edge graticule lines.
- 5. On 8620C Sweep Oscillator, set start-stop for full band and set CW MARKER to a position on CRT one line from the right edge of CRT graticule. (See Figure 3-7.)

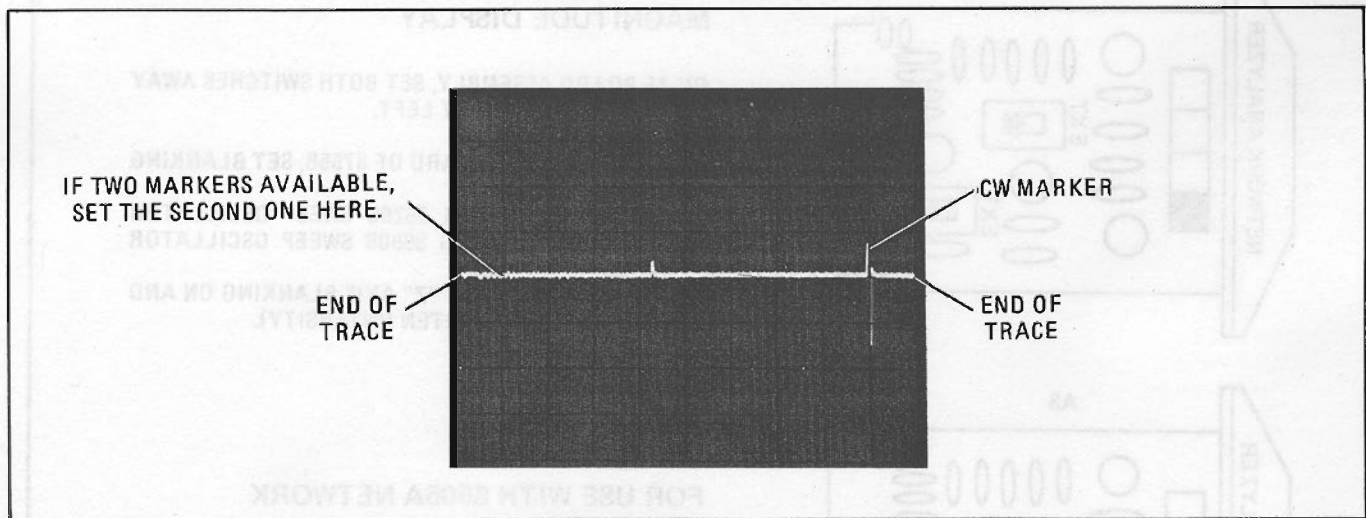

Figure 3-7. Horizontal Display Adjustment

- 6. On 8750A, press then . Adjust front-panel HORIZ POSN and HORIZ GAIN controls to place the left end of trace on left graticule edge line and right end of trace on right graticule edge line. (Ignore the position of the waveform on the trace in this step.)
- 7. On 8755B, press Channel 1 .25 dB/DIV pushbutton. If necessary, adjust Channel 1 VERNIER control to center trace on CRT.

8. On 8750A rear panel, adjust SWP IN GAIN and OFF (offset) controls on A5 Interface Board while alternately pressing the front panel , then pushbuttons. Adjust the controls until the two traces are as near alike as possible and the marker(s) is in the same position horizontally on both traces. Note: GAIN control affects the right side of trace and OFF (offset) affects the entire trace.

VERTICAL TRACE CALIBRATION

9. On 8750A, press then . The trace should be a horizontal line. Adjust front-panel VERT POSN (vertical position) control to place the trace on the center graticule line. Press then move the trace well off the top of CRT with 8755B Channel 1 VERNIER. On 8750A, press , then adjust 8750A front-panel VERT GAIN so the display limits approximately 1/8 inch above the top graticule line. (See Figure 3-8.)
10. Press then adjust trace to the center graticule line with 8755B Channel 1 VERNIER. Press then adjust rear-panel VERT IN OFF to position trace on center graticule line.
11. Press then adjust trace to the top graticule line with 8755B Channel 1 VERNIER. (It may be necessary to change dB/DIV range.) Press then adjust rear-panel VERT IN GAIN to position the trace on the top graticule line.

3-5. FUNCTIONAL TEST OF MAIN FEATURES WITH NETWORK ANALYZER

3-6. The following procedure functionally tests the 8750A. This procedure may be used for incoming inspection or for an operators check to be assured that the major functions of the instrument are working correctly. Use one of the test setups in Figure 3-3, 3-4, or 3-5 and adjust the sweep oscillator for START/STOP sweep mode.

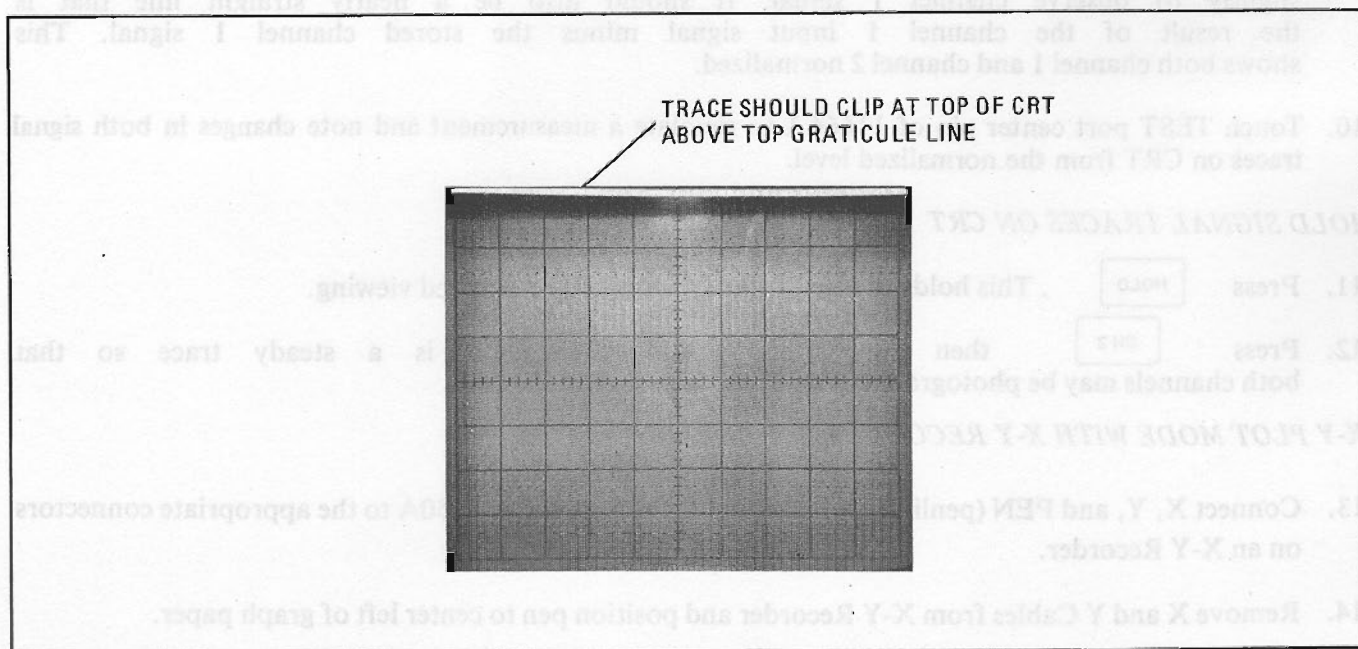

Figure 3-8. Vertical Display Adjustment

1. On 8750A, press , , then , .
2. On 8755B, select DISPLAY "A/R" on channel 1 and "R" on channel 2. Set both VERNIERS to ON. Adjust VERNIERS so both traces are displayed on CRT.

STORE CHANNEL 1 AND RECALL FROM MEMORY

3. On 8750A, press , , and . This stores the trace from channel 1 into Reference Memory.
4. Press pushbutton. The stored channel 1 signal should be a steady trace on the CRT. (Channel 2 is also displayed but it is continually being updated.)
5. Touch TEST port center pin on 11666A and note that channel 2 changes but channel 1 is displayed from Reference Memory and does not change.

STORE CHANNEL 2 THEN RECALL IT FROM MEMORY

6. Press , , and . This stores the trace from channel 2 into Reference Memory.
7. Press and both channel 1 and channel 2 are displayed from Reference Memory. (NOTE: Channel 1 is still operating in "RECALL" mode from step 4.)

DISPLAY INPUT MINUS STORED SIGNAL

8. Press and channel 2 input signal minus previously stored channel 2 signal should be displayed as a nearly straight horizontal line.
9. Press then . Adjust 8755B VERNIER control slightly to observe channel 1 signal. It should also be a nearly straight line that is the result of the channel 1 input signal minus the stored channel 1 signal. This shows both channel 1 and channel 2 normalized.
10. Touch TEST port center pin of 11666A to simulate a measurement and note changes in both signal traces on CRT from the normalized level.

HOLD SIGNAL TRACES ON CRT

11. Press . This holds channel 1 steady for photo or detailed viewing.
12. Press then and channel 2 is a steady trace so that both channels may be photographed together.

X-Y PLOT MODE WITH X-Y RECORDER

13. Connect X, Y, and PEN (penlift) connectors at the rear-panel of 8750A to the appropriate connectors on an X-Y Recorder.
14. Remove X and Y Cables from X-Y Recorder and position pen to center left of graph paper.
15. With X and Y Cables connected to X-Y Recorder and 8750A **NOT** in X-Y Plot mode, position the pen to upper right of graph paper.

16. On 8750A, press . The X-Y recorder should trace the waveform that was displayed on the CRT just before the X-Y Plot mode was started. (The 8750A goes into "HOLD" until the X-Y Plot is completed.)

3-7. ADJUSTMENTS TO MATCH 8750A TO SPECTRUM ANALYZER

- 3-8. Before the 8750A can be used with a Spectrum Analyzer to make measurements, it must be matched to the measurement system as follows:

NOTE

The following procedure is written for 8557A and 8558B Spectrum Analyzers. If you are using some other model spectrum analyzer, the procedure is basically the same but the name of the controls may be different.

1. Connect equipment as shown in Figure 3-9.
2. On 8750A:
 - a. If installed, pull out A5 Spectrum Analyzer Interface board at rear-panel of 8750A. (See Figure 3-10.)
 - b. Set the switch on A5 to the position that matches your spectrum analyzer shown in Figure 3-10.
 - c. Install A5 into the 8750A rear panel.
 - d. Press front-panel .
3. On 8558B, adjust the controls to display the calibration signal trace horizontally at the center of the CRT graticule.

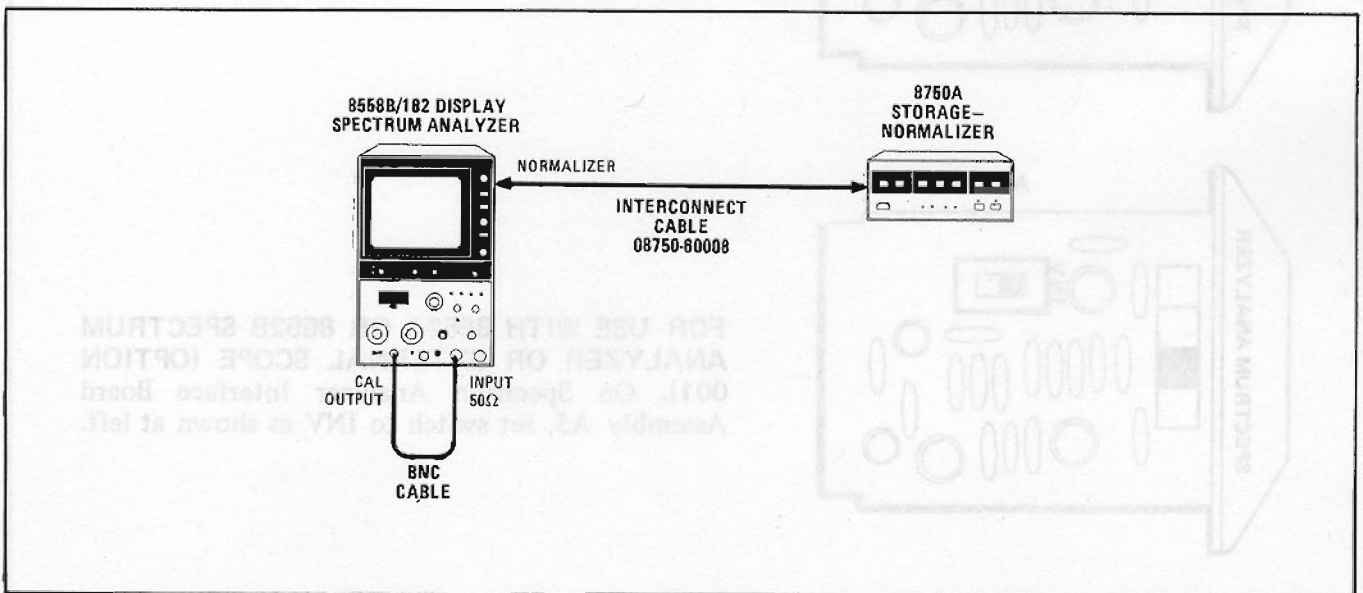

Figure 3-9. Typical Test Setup with Spectrum Analyzer

HORIZONTAL TRACE CALIBRATION

4. On 182 Display, adjust HORIZONTAL POSITION control to center trace horizontally on CRT. If the two end dots are not on the edge graticule lines, the 8558B HORIZ GAIN (horizontal gain) control on the rear panel must be adjusted as follows. Note the position of the trace, then remove the 8558B from the display mainframe. On the rear panel of the 8558B, adjust HORIZ GAIN control counterclockwise to compress the trace or clockwise to expand the trace. Reinstall the 8558B into the display and check the trace. Readjust HORIZONTAL POSITION control on the display to center the trace. The 8558B adjustment may have to be done several times to get both ends of the trace over the edge graticule lines. (If other than 8557A or 8558B Spectrum Analyzer is being used, refer to the appropriate operating and service manual for Vertical and Horizontal calibration.)
5. Readjust 8558B tuning to place the calibration signal trace in the center of the CRT. Select LINEAR mode. Expand the signal trace so it covers the width of the CRT graticule as shown in Figure 3-11.

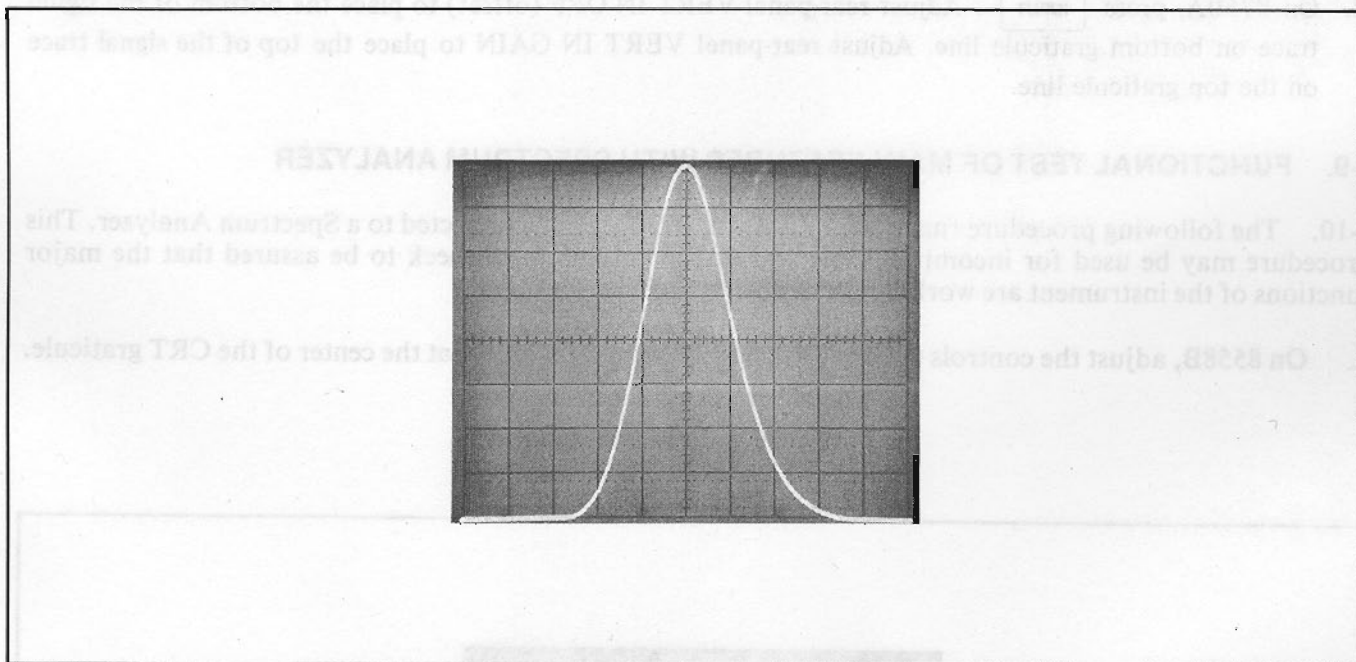

Figure 3-11. Spectrum Analyzer Calibration Signal used to Adjust 8750A

6. On 8750A, press . Adjust front-panel HORIZ POSN and HORIZ GAIN controls to place the left end of trace on left graticule edge line and right end of trace on right graticule edge line. (Ignore the position or content of the waveform on the trace in this step.)
7. On 8750A, press . On 8558B, readjust TUNING control to center the test signal trace (Figure 3-11). On 8750A press the front-panel pushbutton. Adjust the rear-panel SWP IN OFF (offset) to center the trace. Press pushbutton and note position of edges of test signal. Press and adjust rear panel SWP IN GAIN to place the edges of the test signal trace in the same relative horizontal position as noted above in bypass mode.

VERTICAL TRACE CALIBRATION

8. On 8750A, press , , , then . The CRT trace should look like Figure 3-12. Adjust front-panel VERT POSN to place the CRT trace on the center graticule line.
9. On 8558B, adjust TUNING control slightly to obtain a trace that goes off screen on both the top and bottom or flattens on top and bottom. (See Figure 3-13.)
10. Adjust the front-panel VERT GAIN so the flat cutoff sections of the trace both move outside the CRT graticule area on the top and bottom. (See Figure 3-13.)
11. On 8750A, press . Adjust the top of the test signal trace to the top graticule line.
12. On 8750A, press . Adjust rear-panel VERT IN OFF (offset) to place the bottom of the signal trace on bottom graticule line. Adjust rear-panel VERT IN GAIN to place the top of the signal trace on the top graticule line.

3-9. FUNCTIONAL TEST OF MAIN FEATURES WITH SPECTRUM ANALYZER

3-10. The following procedure functionally tests the 8750A when connected to a Spectrum Analyzer. This procedure may be used for incoming inspection or for an operators check to be assured that the major functions of the instrument are working correctly.

1. On 8558B, adjust the controls to display the calibration signal trace at the center of the CRT graticule.

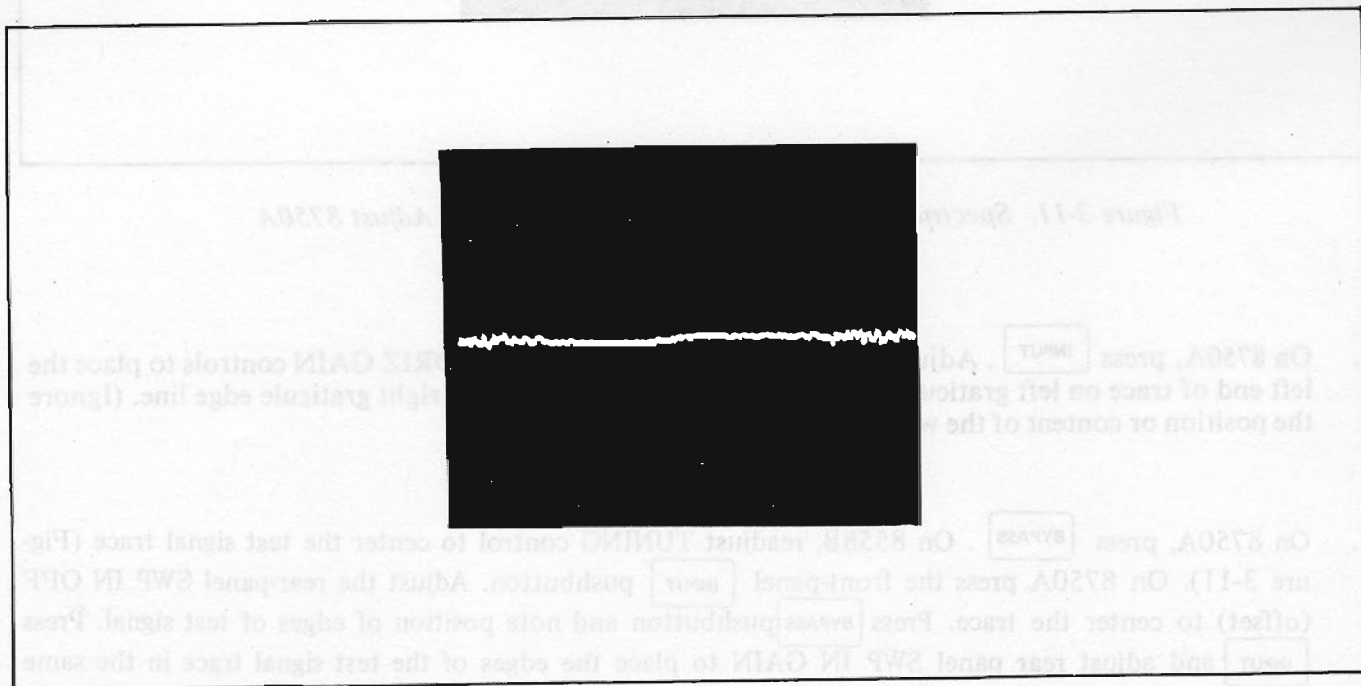

Figure 3-12. CRT Trace Showing Front-Panel VERT POSN Control Correctly Adjusted

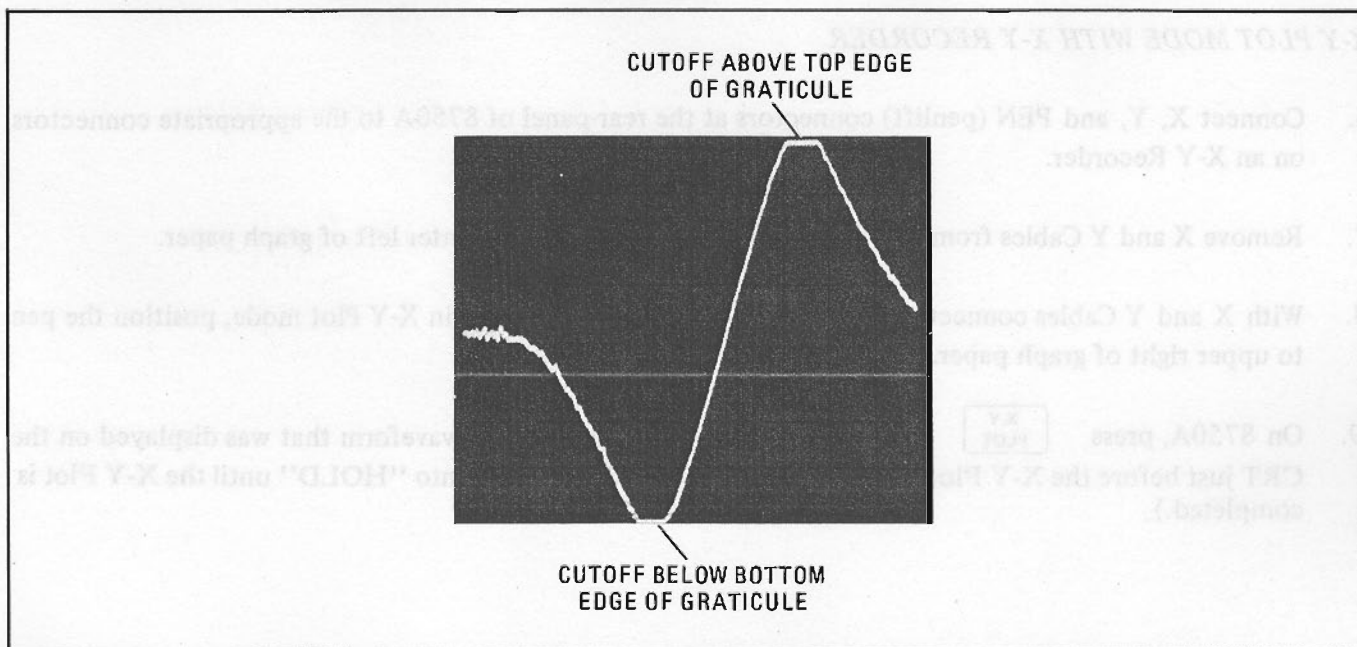

Figure 3-13. CRT Trace Showing Front-Panel VERT GAIN Correctly Adjusted

VIEW A SINGLE TRACE

- On 8750A, press , . This displays a flicker-free trace that is refreshed during each sweep of the Spectrum Analyzer. Note that trace B is in INPUT mode, and trace A is blanked.

VIEW CHANNEL A WITH CHANNEL B HELD

- On 8750A, press , , . Press , then . On 8558B, adjust TUNING control. The A trace should be adjustable and the B channel should be fixed. Note that the last mode the B trace was in was HOLD. It still operates in that mode, displaying the B trace from temporary memory.

DISPLAY BOTH CHANNEL A AND B HELD ON CRT FOR PHOTO

- On 8750A, press , , , , . Adjust 8558B TUNING slightly to move the A trace away from the B trace, then on 8750A, press . Both Channel A and B traces should be displayed on CRT from temporary memory.

DISPLAY INPUT SIGNAL MINUS THE STORED SIGNAL FROM MEMORY

- On 8750A, press , , , then . Adjust the 8558B TUNING control to move the trace across the CRT. The displayed trace is the input signal minus the previously stored signal from memory.

X-Y PLOT MODE WITH X-Y RECORDER

6. Connect X, Y, and PEN (penlift) connectors at the rear-panel of 8750A to the appropriate connectors on an X-Y Recorder.
7. Remove X and Y Cables from X-Y Recorder and position pen to center left of graph paper.
8. With X and Y Cables connected to X-Y Recorder and 8750A **NOT** in X-Y Plot mode, position the pen to upper right of graph paper.
9. On 8750A, press  . The X-Y Recorder should trace the waveform that was displayed on the CRT just before the X-Y Plot mode was started. (The 8750A goes into "HOLD" until the X-Y Plot is completed.)

SECTION IV PERFORMANCE TEST

4-1. INTRODUCTION

4-2. This section contains procedures to test the specifications of the 8750A. These procedures assume the operator has a good knowledge of the operation of the Network Analyzer or Spectrum Analyzer used with the 8750A. Two groups of test procedures are described. One group, starting with Paragraph 4-3, tests the 8750A in a Network Analyzer system; the other group, starting with Paragraph 4-6, tests the 8750A in a Spectrum Analyzer system. Use whichever group of tests satisfies the requirements of your 8750A application.

NOTE

For an abbreviated test that will check the overall operation of the 8750A, perform either the **FUNCTIONAL TEST WITH NETWORK ANALYZER** or the **FUNCTIONAL TEST WITH SPECTRUM ANALYZER** described in Section III. Be aware, however, that the Functional Tests in Section III do not necessarily prove the instrument is operating within its listed specifications.

PERFORMANCE TESTS

4-3. PERFORMANCE TEST WITH 8755B NETWORK ANALYZER

4-4. X-Y Recorder Output Test

1. Connect equipment as shown in Figure 4-1. Set Sweep Oscillator for START/STOP mode.
2. On 8750A, press , then .
3. On 8755B, press Channel 1 DISPLAY A/R. Adjust Channel 1 VERNIER control to place the trace as low as possible on the CRT. At Channel 2, press one of the DISPLAY buttons part way in to turn off Channel 2. Adjust Channel 1 VERNIER control to place the trace as low as possible on the CRT. The trace should go into a straight line or off the screen below the bottom graticule line.
4. On Oscilloscope:

Channel A VOLTS/DIV2
 Channel A trace Bottom graticule line is
 zero-volt reference

NOTE

During X-Y Plot mode, the Network Analyzer CRT display will not sweep full width.

5. Before initiating an X-Y plot, determine the "true full scale" reference value for X and Y Recorder OUTPUT. With the oscilloscope connected to X RECORDER OUTPUT, the trace should be near +1 Vdc; note exact reading. Connect oscilloscope to Y RECORDER OUTPUT and the trace should be near +4 Vdc; note exact reading. These two readings are the "true full scale" reference values for X and Y recorder outputs.
-

6. Connect oscilloscope to X RECORDER OUTPUT, then press X-Y PLOT. The trace should go to 0 Vdc ± 20 mV then slowly return to "true full scale" reference value for X noted in step 5 above. At the end of the plot, the trace should not step more than ± 30 mV.
7. Connect oscilloscope to Y RECORDER OUTPUT, then press X-Y PLOT. The trace should go to approximately -4 Vdc for approximately 30 seconds, then return to "true full scale" reference value for Y noted in step 5 above ± 0.12 Vdc
8. On 8755B, adjust Channel 1 VERNIER control to place the trace as high as possible on the CRT. It should go to a straight line or off the CRT above the top graticule line.
9. On 8750A, press X-Y PLOT. The trace should go to "true full scale" reference value for Y noted in step 5 above ± 0.12 Vdc during the plot time. At the end of the plot, the trace should not step more than ± 0.12 Vdc.

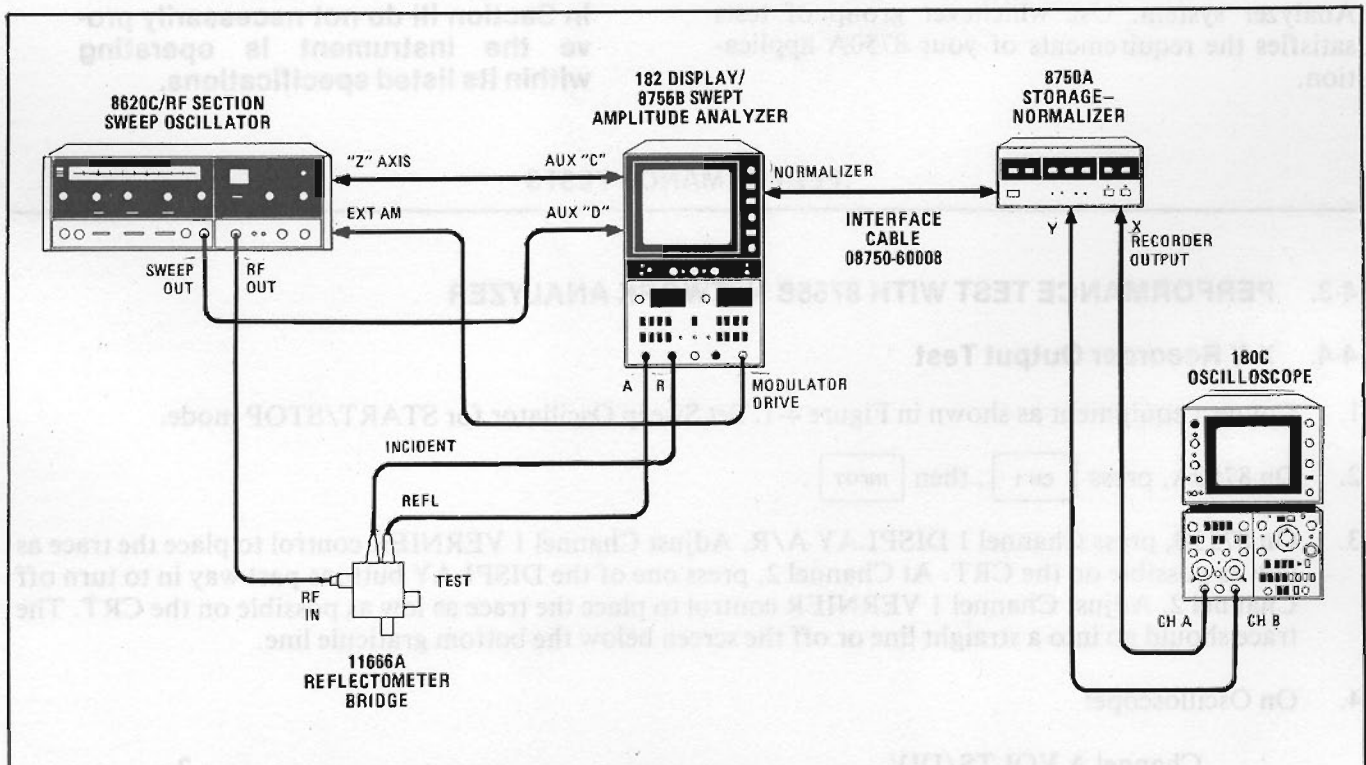

EQUIPMENT FOR NETWORK ANALYZER PERFORMANCE TEST

1. Sweep Oscillator HP 8620C/Rf Section
2. Swept Amplitude Analyzer HP 8755B/182 Display
3. Reflectometer Bridge..... HP 11666A
4. Oscilloscope HP 180C/1805A/1825A
5. Normalizer Interface Cable HP 08750-60008

Figure 4-1. Typical Test Setup for 8750A Performance Tests Using a Network Analyzer

PERFORMANCE TESTS

4-5. Sweep Speed Test

SWEEP TIME 0.01 SECOND

1. Connect equipment as shown in Figure 4-1.
2. On Sweep Oscillator, select START/STOP mode, set MARKER to OFF and set sweep time to 0.01 Seconds/Sweep.
3. On 8750A, press .
4. On 8755B, display only channel 1 and adjust channel 1 REFERENCE LEVEL VERNIER control to position the trace near the center of CRT.
5. On 8750A, press the following pushbuttons.
 - a.
 - b.
 - c.
 - d.

The trace should be a straight line with no blank sections in the line. Also, the line should have no noise movement since it is in "HOLD" mode.

NOTE

The preceding steps stored the input into memory, then subtracted the signal in memory from the input signal. The resultant was the zero-volt signal. This zero-volt signal was then placed in "HOLD" memory and displayed as a fixed trace on the CRT.

SWEEP TIME 100 SECONDS

6. On Sweep Oscillator, set sweep time to approximately 100 Seconds/Sweep.
7. On 8750A, press . The trace on CRT should update as it sweeps across the screen. The trace may be observed stepping to each of the 256 horizontal storage positions.

NOTE

Storage update may be more easily observed by touching the TEST port center conductor of the 11666A bridge with your finger for one sweep. Then remove your finger from the TEST port and allow the next sweep to update the trace.

8. Set up equipment to test channel 2 as follows:
 - a. On 8750A, press , then .
 - b. On 8755B, display only Channel 2. Turn on Channel 2 VERNIER and adjust trace with Channel 2 VERNIER to place the trace near the center of the CRT.
9. Repeat previous steps 5 through 7 to test Channel 2 operation.

PERFORMANCE TESTS

4-6. PERFORMANCE TEST WITH 8558B SPECTRUM ANALYZER

4-7. X-Y Recorder Output Test

1. Connect equipment as shown in Figure 4-2.

2. On 8750A, press Channel , then

3. On 8558B, adjust TUNING control to place the trace in the center of the CRT.

4. On oscilloscope:

Channel A VOLTS/DIV2
 Channel A trace Bottom graticule line is zero-volt reference

NOTE

During X-Y Plot mode, the Spectrum Analyzer CRT display will not sweep full width.

5. Before initiating an X-Y plot, determine the "true full scale" reference value for X and Y Recorder OUTPUT. With the oscilloscope connected to X RECORDER OUTPUT the trace should be near +1 Vdc; note exact reading. Connect oscilloscope to Y RECORDER OUTPUT and trace should be near +4 Vdc; note exact reading. These two readings are the "true full scale" reference values for X and Y recorder outputs.

6. Connect oscilloscope to X RECORDER OUTPUT, then press . The trace should go to 0 Vdc ± 20 mV then slowly return to "true full scale" reference value for X noted in step 5 above. At the end of the plot the trace should not step more than ± 30 mV.

7. Connect oscilloscope to Y RECORDER OUTPUT, then press . The trace should change between approximately +4 Vdc and -4 Vdc, tracing out the displayed signal, then it should return to "true full scale" reference value for Y noted in step 5 above ± 0.12 Vdc.

NOTE

If the entire trace cannot be moved off screen at the top in step 8, note only the value of the trace that is off screen in step 9.

8. On 8758B, adjust REFERENCE LEVEL dBm control to -90 dBm to place the trace as high as possible on the CRT. The trace should go to a straight line or off the CRT above the top graticule line.

9. On 8750A, press . The oscilloscope trace should go to "true full scale" reference value for Y noted in step 5 above ± 0.12 Vdc during the plot time. At the end of the plot, the trace should not step more than ± 0.12 Vdc.

PERFORMANCE TESTS

4-8. Sweep Speed Test

SWEEP TIME 10 MILLISECONDS

1. Connect equipment as shown in Figure 4-2.
2. On 8558B, set sweep time to 1 millisecond/Division.
3. On 8750A, press the following:

- a. Channel
- b.
- c.
- d.
- e.

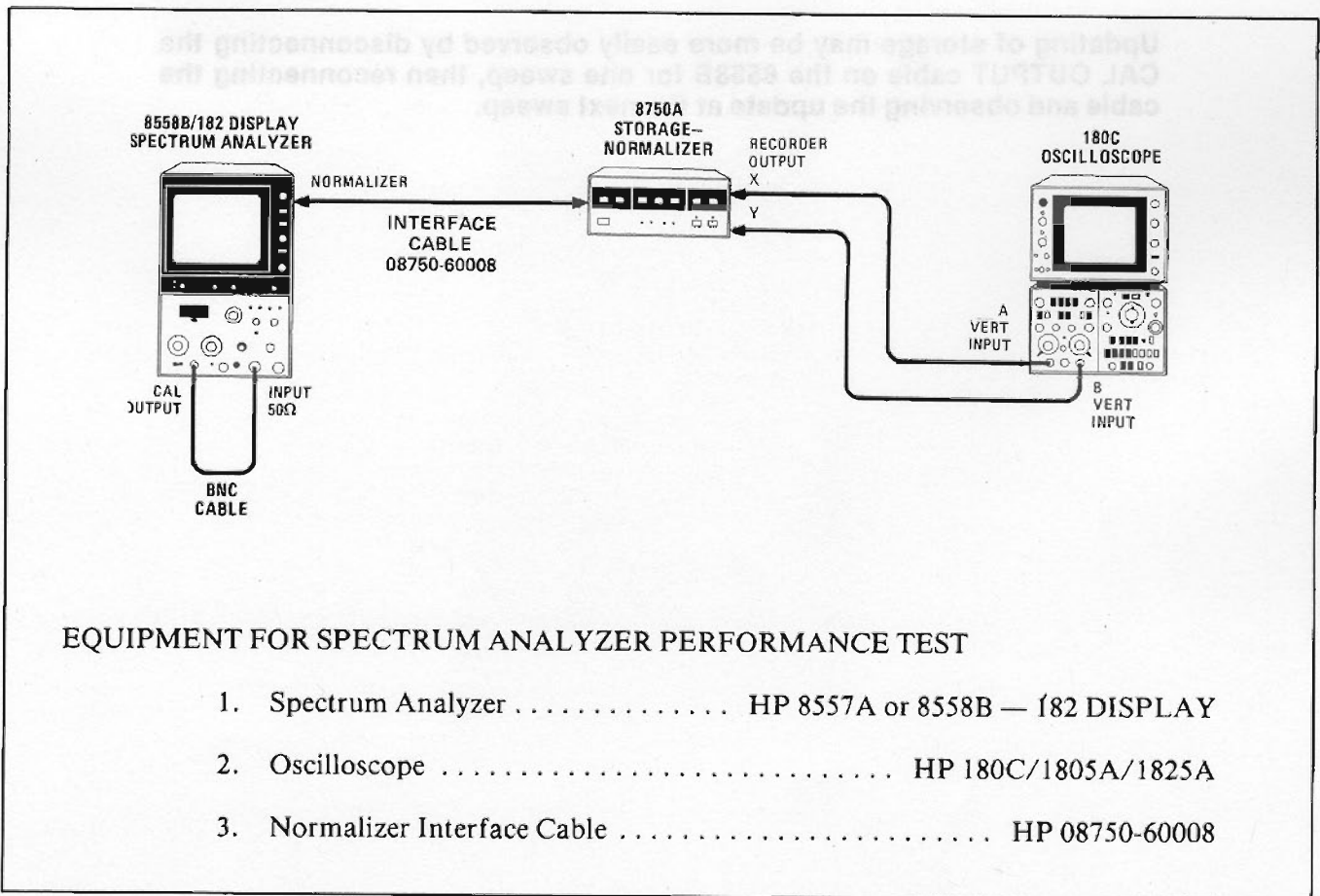

Figure 4-2. Typical Test Setup for 8750A Performance Tests Using a Spectrum Analyzer

PERFORMANCE TESTS

The trace should be an overall straight line with small variations along the line. There should be no blank sections along the line. Also, the line should have no noise movement since it is in "HOLD" mode.

NOTE

The preceding steps stored the input into memory, then subtracted the signal in memory from the input signal. The result was a near zero-volt signal. This zero-volt signal was then placed in "HOLD" memory and displayed as a fixed trace on the CRT.

SWEEP TIME 100 SECONDS

4. On the 8558B, set sweep time to 10 Seconds/Division.
5. On the 8750A, press . The trace on the CRT should update as it sweeps across the screen. Trace may be observed stepping to each of the 256 horizontal storage positions.

NOTE

Updating of storage may be more easily observed by disconnecting the CAL OUTPUT cable on the 8558B for one sweep, then reconnecting the cable and observing the update at the next sweep.



EQUIPMENT FOR SPECTRUM ANALYZER PERFORMANCE TEST

1. Spectrum Analyzer	HP 8558A or 8558B — 182 DISPLAY
2. Oscilloscope	HP 1800/1802A/1822A
3. Normalizer Interface Cable	HP 08750-60008

Figure 4-2. Typical Test Setup for 8750A Performance Test Using Spectrum Analyzer

SECTION V ADJUSTMENTS

5-1. INTRODUCTION

5-2. This section contains the adjustment procedures you may have to perform to recalibrate the Storage-Normalizer following a repair, or as part of a periodic maintenance program.

NOTE

This section of the manual covers only the 8750A's internal adjustments. External adjustments, which are made to adapt the 8750A to particular measurement applications, are covered in the Operation Section (Section III).

WARNING

The adjustments described in this section are performed with ac power supplied to the 8750A and with the 8750A's top protective cover removed. Energy at many points inside the 8750A will, if contacted, cause electrical shock.

5-3. Although the 8750A Storage-Normalizer has been designed in accordance with international safety standards, the procedures, cautions, and warnings in this manual must be strictly adhered to in order to prevent personal injury and to keep the instrument in a safe operating condition. All work on the instrument with power applied, and that necessitates removal of the instrument's top or

bottom cover, must be performed only by a qualified electronics service technician who is aware of the hazard involved.

5-4. EQUIPMENT REQUIRED

5-5. Before you start the adjustment procedures, you must set up the 8750A in either a Network Analyzer system as shown in Figure 4-1, or in a Spectrum Analyzer system as shown in Figure 4-2. The only equipment you will need beyond that in the system setup is an adjustment tool and an oscilloscope with a 10:1 test probe. (Recommended test equipment is listed in Table 1-4.)

5-6. ADJUSTMENTS AND TEST POINTS LOCATIONS

5-7. All of the calibration adjustments and test points in the 8750A are on the Analog Board Assembly, A2, and are easily accessible when the top cover of the instrument is removed. These controls and test points are listed and functionally described in Table 5-1. Their locations are shown in Figure 5-7, a fold-out page at the back of this section.

5-8. COVER REMOVAL

5-9. The top and bottom covers of the 8750A are secured identically. To remove a top or bottom cover, remove the two screws (visible from rear of instrument) at the left and right corners that fasten the cover to the rear panel. Then slide the cover toward the rear of the instrument until the cover front edge clears the detent in the front panel frame.

Table 5-1. Adjustment Controls and Test Points

Schematic Name	Reference Designator	Function	Procedure (paragraph)
TRIANGLE OFFSET (B)	A2R17	Adjusts offset of triangle waveform output from Triangle Wave Generator circuit which drives Line Generator circuit.	5-13
Y GAIN (C)	A2R19	Adjusts magnitude of +V reference input to Y Digital-to-Analog Converter (DAC) U16 (pin 14).	5-15
GAIN BALANCE (D)	A2R20	Adjusts magnitude of +V reference input to X Digital-to-Analog Converter (DAC) U22 (pin 14). Is used to balance the two DAC's.	5-14
PLOT X (F)	A2R46	Adjusts gain of plot X output.	5-16
STEP SIZE (A)	A2R49	Adjusts step size of Staircase Generator circuit output to Horizontal Sample Generator circuit.	5-12
COMPENSATION (E)	A2C12	Adjusts compensation applied to Y DAC U16. Is used with (D) to balance the two DAC's.	5-14
DIGITAL GND	A2TP1	Ground return for +5 volts power applied to digital IC packages. Common with both analog grounds when A2 is plugged into Motherboard.	
HDV HOLD ON	A2TP2	Used for tests or troubleshooting to apply +5 volts to CLEAR input (pin 10) of F-F U1B to set HDV output at P1-2.	
SWP IN	A2TP3	Used to check SWP IN (0-3V ramp) applied to Horizontal Sample Generator circuit from P1-5.	5-11
Triangle Offset	A2TP4	Used to check offset (B) adjustment.	5-13
Y GEN Output	A2TP5	Used to check Y GEN output from Vertical Output Line Generator circuit to P1-46.	5-14, 5-15
Staircase	A2TP6	Used to check Staircase Generator circuit output to Horizontal Sample Generator circuit.	5-12
Y IN	A2TP7	Used to check Y IN applied to Input Sample/ Hold Peak Detector circuit at P1-6.	
X RAMP	A2TP8	Used to check X RAMP output from X Ramp Generator circuit at P1-44.	5-16

ADJUSTMENTS

5-10. SWEEP INPUT GAIN AND OFFSET

Oscilloscope: A2TP3 Sweep Input
Controls: Rear Panel A5 Interface Board
 SWP IN GAIN
 SWP IN OFFSET (OFF)

Adjustment Description: Adjust sweep input controls for -0.2 to $+3.2$ Volt ramp as shown in Figure 5-1.

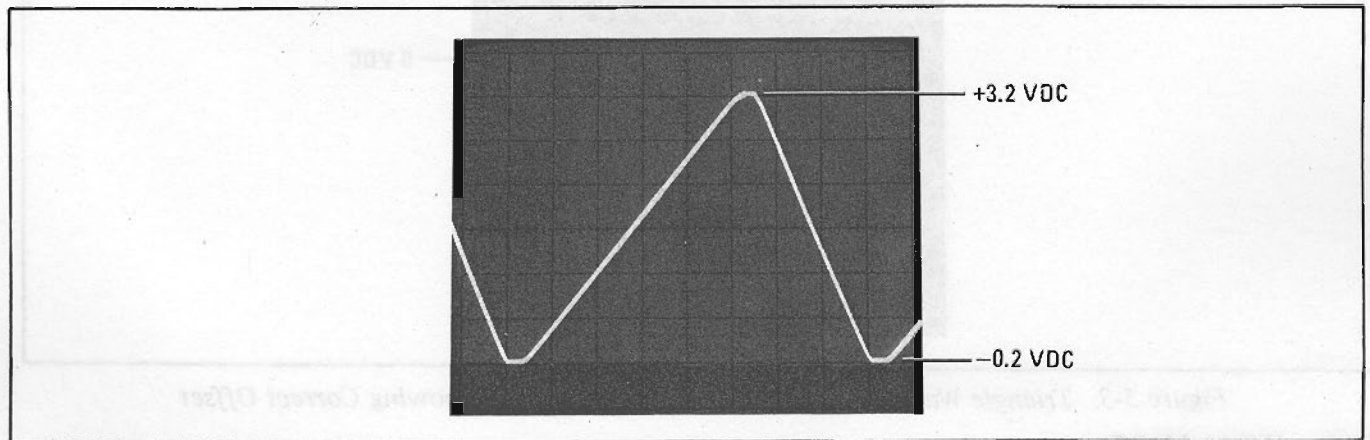

Figure 5-1. Sweep Input Waveform at A2TP3

5-11. STEP SIZE

Oscilloscope: A2TP6 Staircase
Control: "A" Step Size A2R49

Adjustment Description: Adjust "A" so the waveform just reaches $+3$ Vdc ± 0.1 Vdc as shown in Figure 5-2.

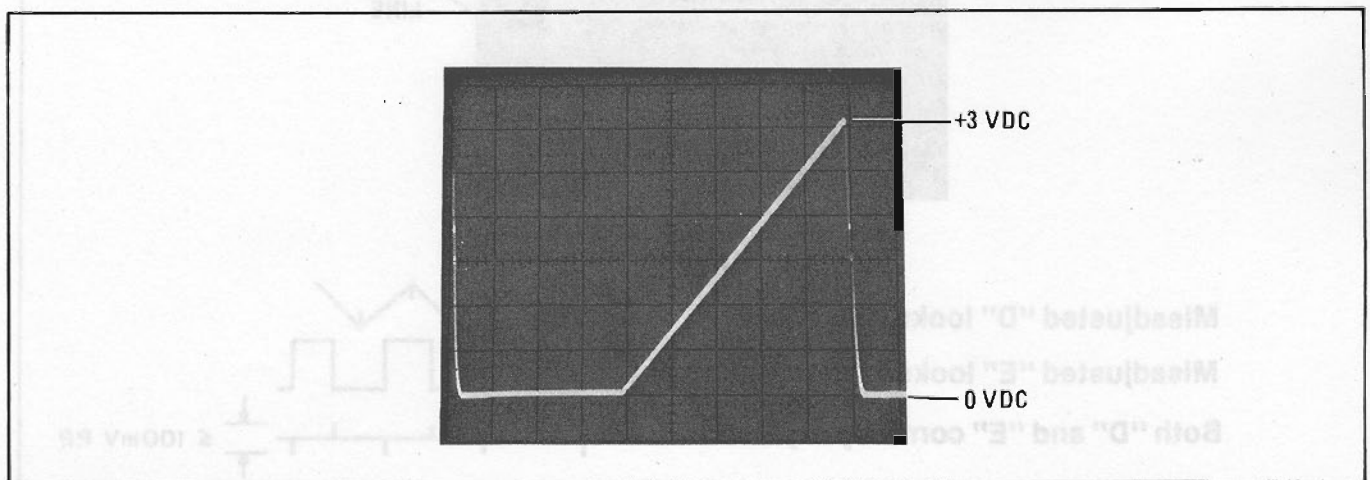

Figure 5-2. Stairstep Waveform at A2TP6

ADJUSTMENTS

5-12. TRIANGLE OFFSET

Oscilloscope: A2TP4 Triangle

Control: "B" Triangle Offset A2R17.

Adjustment Description: Adjust "B" so the top peak of the triangle waveform just starts to flatten, then back up the control just until the top of the waveform is a sharp peak again as shown in Figure 5-3.

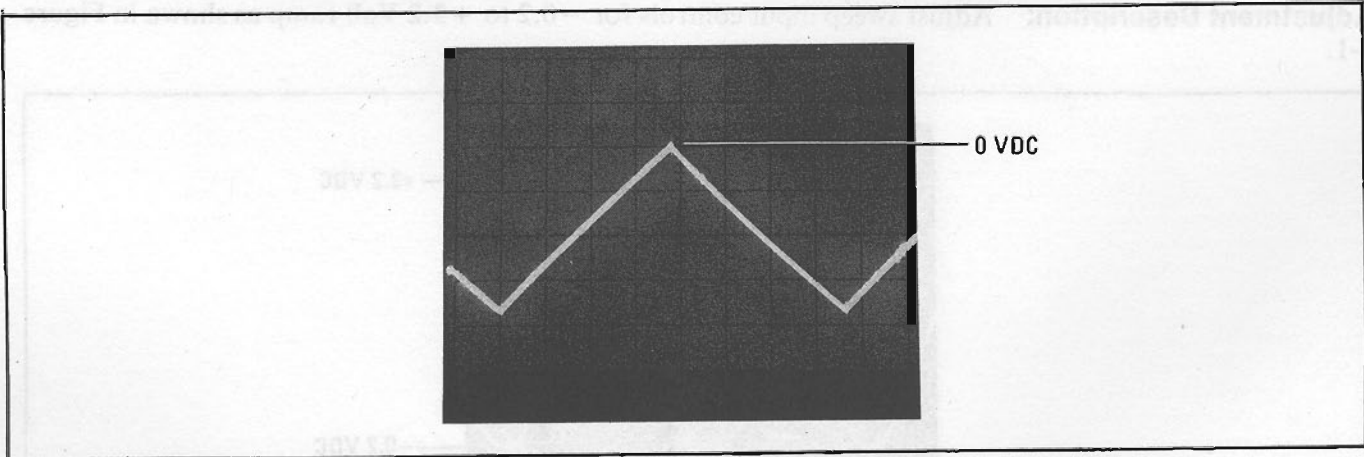

Figure 5-3. Triangle Wave Generator Waveform at A2TP4 Showing Correct Offset

5-13. Y BALANCE

Oscilloscope: A2TP5 Y-Generator, 0.5V/DIV, 0.5 ms/DIV, Expand X10, Vertical AC-Coupled

Controls: "D" Gain Balance A2R20

"E" Compensation A2C12

Adjustment Description: Adjust network analyzer or spectrum analyzer to move the CRT trace off screen at top so it "clips" at the top of screen. Adjust "D" and "E" for straight thin line at top of trace as shown in Figure 5-4.

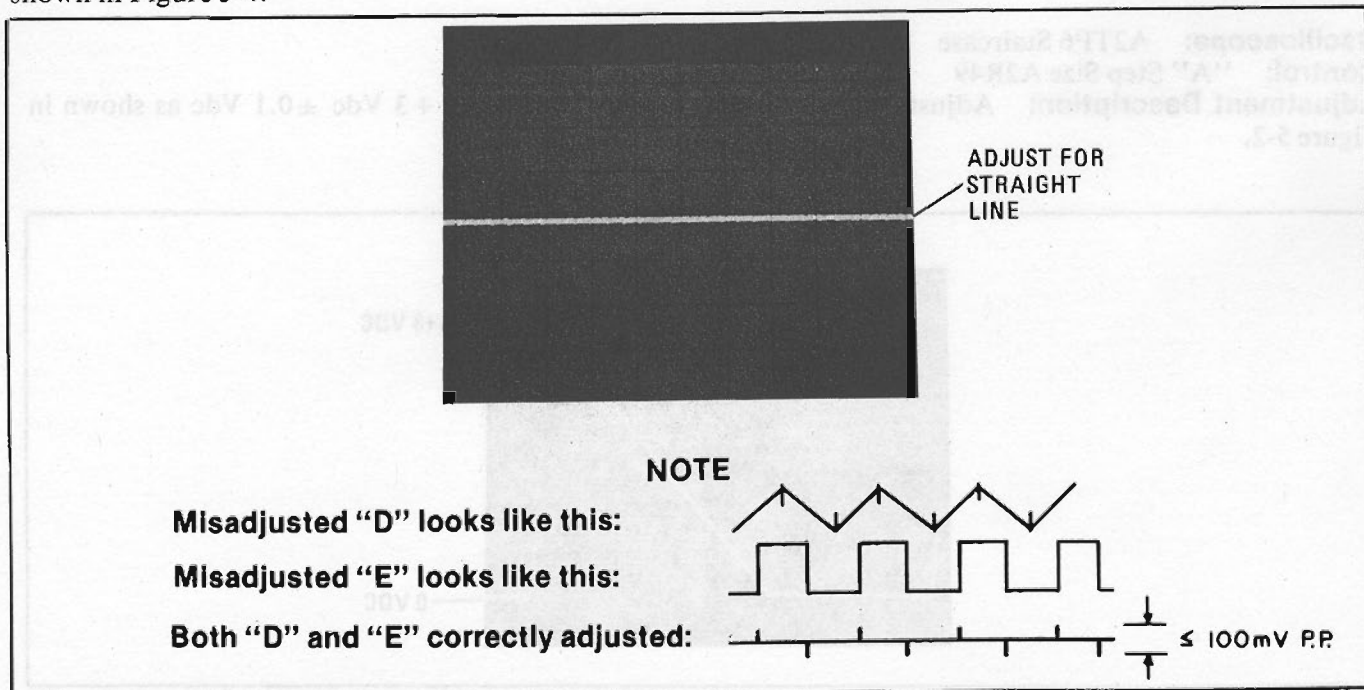

Figure 5-4. Y-Generator Waveform at A2TP5. Expanded to show Correct Balance and Compensation

ADJUSTMENTS

5-14. Y GAIN

Oscilloscope: A2TP5 Y-Generator

Control: "C" Y GAIN A2R19

Adjustment Description:

- Connect dc coupled oscilloscope to 8750A rear panel Y RECORDER OUTPUT and note "true full scale" reference line position (near +4 Vdc).
- Connect dc coupled oscilloscope to A2TP5 and adjust "C" so the top of the waveform (Figure 5-5) is the same as the "true full scale" reference line noted in step a ± 0.12 volts.

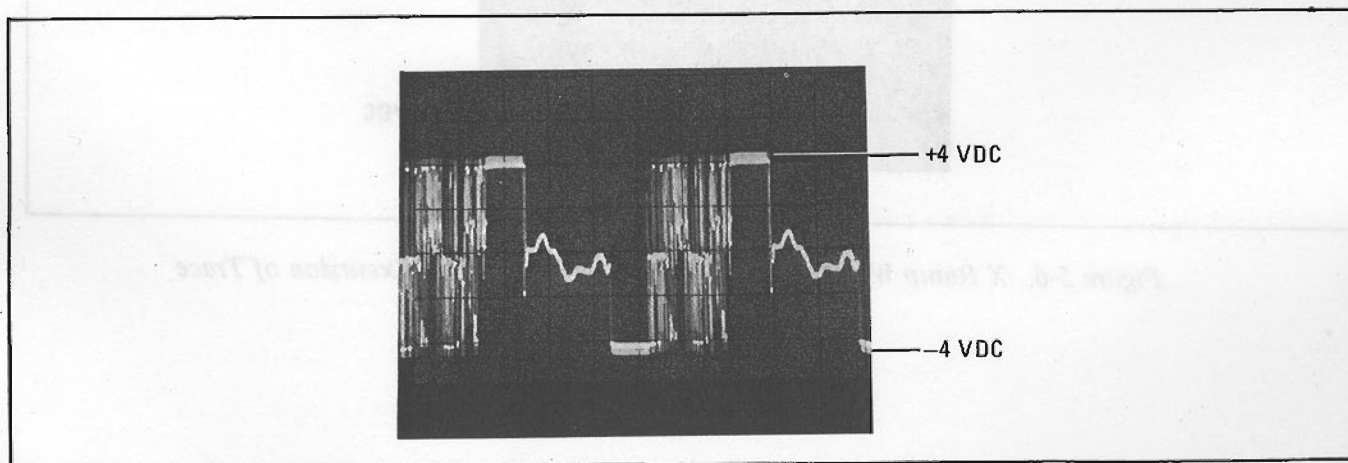

Figure 5-5. Y-Generator Waveform at A2TP5

5-15. X RAMP

Oscilloscope: A2TP8 X-Ramp

Controls: "F" PLOT X A2R46
Front-Panel X-Y PLOT pushbutton.

Adjustment Description:

- Connect dc coupled oscilloscope to 8750A rear panel X RECORDER OUTPUT and note "true full scale" reference line position (near +1 Vdc).
- Connect dc coupled oscilloscope to A2TP8.

ADJUSTMENTS

- c. Press front-panel . The maximum positive position of trace at the end of the plot cycle (Figure 5-6) should be the same as the "true full scale" reference line noted in step a. If not, adjust "F" then press . Repeat this procedure until the X ramp ends on the reference line noted in step a ± 30 mV.

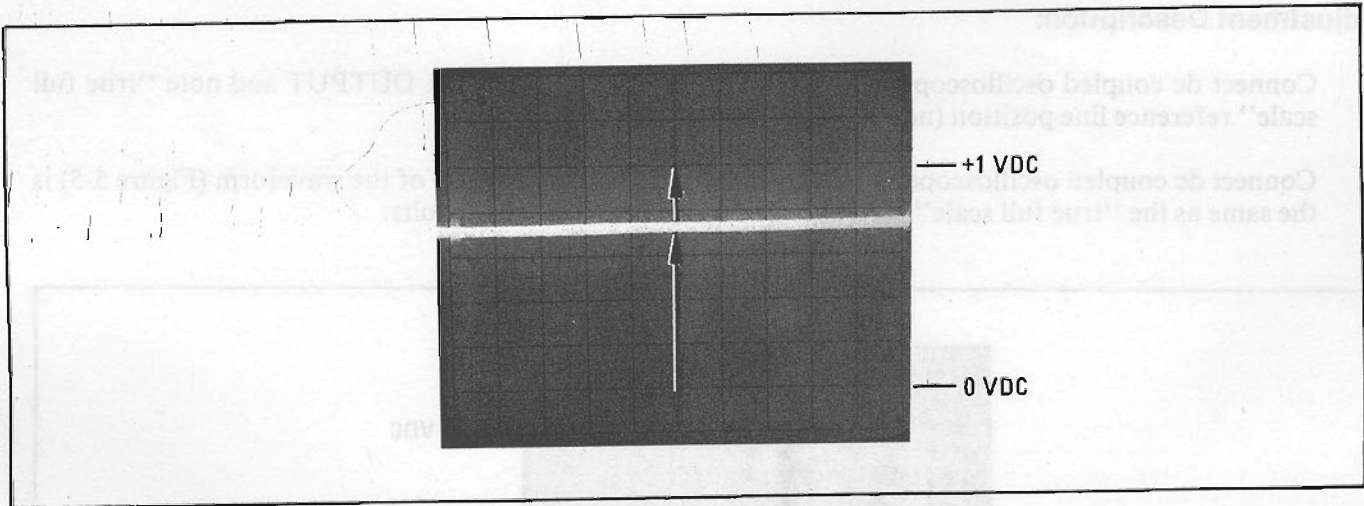

Figure 5-6. X Ramp Waveform Showing Slow 0 to +1 Vdc Excursion of Trace

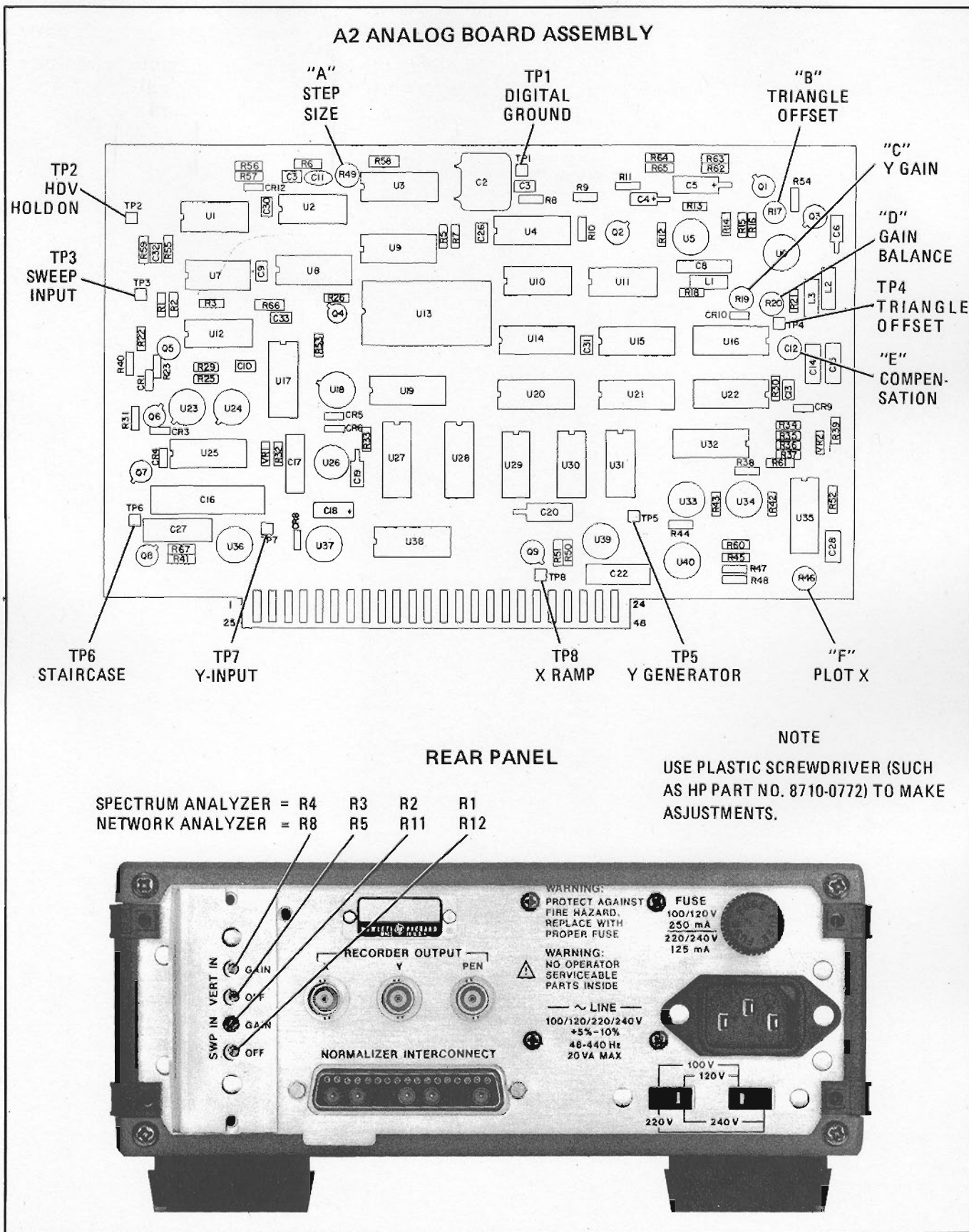

Figure 5-7. Location of Adjustments

SECTION VI REPLACEABLE PARTS

6-1. INTRODUCTION

6-2. This section contains lists of abbreviations and replaceable parts, and information for ordering a replaceable part.

6-3. ABBREVIATIONS

6-4. Table 6-1 lists abbreviations used in the replaceable parts list, on schematic and block diagrams, and in the text of the manual. Abbreviations that would normally appear in lower case letters or a mixture of lower case and capitals, are always all capitals in the replaceable parts list. For abbreviations that appear in this manual in more than one form, each form of the abbreviation is listed.

6-5. REPLACEABLE PARTS LIST

6-6. The list of replaceable parts, Table 6-2, is arranged as follows:

- a. Electrical assemblies and their components in alpha-numerical order by reference designation.
Chassis-mounted parts in alpha-numeric order by reference designation.
- c. Cabinet parts and miscellaneous hardware.

The information given in the list for each part consists of:

- a. The Hewlett-Packard part number.
- b. The total quantity in the instrument.
- c. A description of the part.
- d. A manufacturer of the part in a five-digit code.
- e. The manufacturer's code number for the part.

The total quantity for each part is given only once — at the first appearance of the part number in the list.

6-7. ORDERING INFORMATION

6-8. To order a part listed in the replaceable parts list, quote the Hewlett-Packard part number, indicate the quantity desired, and address the order to the nearest Hewlett-Packard office.

6-9. To order a part that is not listed in the replaceable parts list, indicate the instrument name and Model number (Model 8750A Storage-Normalizer), the instrument's serial number, the description and function of the part, and the number of parts required. Address the order to the nearest Hewlett-Packard office.

Table 6-1. Reference Designations and Abbreviations

REFERENCE DESIGNATIONS

A assembly	E miscellaneous electrical part	P electrical connector (movable portion); plug	U integrated circuit; microcircuit
AT attenuator; isolator; termination	F fuse	Q transistor; SCR; triode thyristor	V electron tube
B fan; motor	FL filter	R resistor	VR voltage regulator; breakdown diode
BT battery	H hardware	RT thermistor	W cable; transmission path; wire
C capacitor	HY circulator	S switch	X socket
CP coupler	J electrical connector (stationary portion); jack	T transformer	Y crystal unit (piezo-electric or quartz)
CR diode; diode thyristor; varactor	K relay	TB terminal board	Z tuned cavity; tuned circuit
DC directional coupler	L coil; inductor	TC thermocouple	
DL delay line	M meter	TP test point	
DS annunciator; signaling device (audible or visual); lamp; LED	MP miscellaneous mechanical part		

ABBREVIATIONS

A ampere	COEF coefficient	EDP electronic data processing	INT internal
ac alternating current	COM common	ELECT electrolytic	kg kilogram
ACCESS accessory	COMP composition	ENCAP encapsulated	kHz kilohertz
ADJ adjustment	COMPL complete	EXT external	kΩ kilohm
A/D analog-to-digital	CONN connector	F farad	kV kilovolt
AF audio frequency	CP cadmium plate	FET field-effect transistor	lb pound
AFC automatic frequency control	CRT cathode-ray tube	F/F flip-flop	LC inductance-capacitance
AGC automatic gain control	CTL complementary transistor logic	FH flat head	LED light-emitting diode
AL aluminum	CW continuous wave	FIL H fillister head	LF low frequency
ALC automatic level control	cw clockwise	FM frequency modulation	LG long
AM amplitude modulation	cm centimeter	FP front panel	LH left hand
AMPL amplifier	D/A digital-to-analog	FREQ frequency	LIM limit
APC automatic phase control	dB decibel	FXD fixed	LIN linear taper (used in parts list)
ASSY assembly	dBm decibel referred to 1 mW	g gram	lin linear
AUX auxiliary	dc direct current	GE germanium	LK WASH lock washer
avg average	deg degree (temperature interval or difference)	GHz gigahertz	LO low; local oscillator
AWG American wire gauge	° degree (plane angle)	GL glass	LOG logarithmic taper (used in parts list)
BAL balance	°C degree Celsius (centigrade)	GND ground(ed)	log logarithm(ic)
BCD binary coded decimal	°F degree Fahrenheit	H henry	LPF low pass filter
BD board	°K degree Kelvin	h hour	LV low voltage
BE CU beryllium copper	DEPC deposited carbon	HET heterodyne	m meter (distance)
BFO beat frequency oscillator	DET detector	HEX hexagonal	mA milliampere
BH binder head	diam diameter	HD head	MAX maximum
BKDN breakdown	DIA diameter (used in parts-list)	HDW hardware	MΩ megohm
BP bandpass	DIFF AMPL differential amplifier	HF high frequency	MEG meg (10 ⁶) (used in parts list)
BPF bandpass filter	div division	HG mercury	MET FLM metal film
BRS brass	DPDT double-pole, double-throw	HI high	MET OX metallic oxide
BWO backward-wave oscillator	DR drive	HIP Hewlett-Packard	MF medium frequency; microfarad (used in parts list)
CAL calibrate	DSB double sideband	HPF high pass filter	MFR manufacturer
ccw counter-clockwise	DTL diode transistor logic	HR hour (used in parts list)	mg milligram
CER ceramic	DVM digital voltmeter	HV high voltage	MHz megahertz
CHAN channel	ECL emitter coupled logic	Hz Hertz	mH millihenry
cm centimeter	EMF electromotive force	IC integrated circuit	mho mho
CMO cabinet mount only		ID inside diameter	MIN minimum
COAX coaxial		IF intermediate frequency	min minute (time)
		IMPG impregnated	' minute (plane angle)
		in inch	MINAT miniature
		INCD incandescent	mm millimeter
		INCL include(s)	
		INP input	
		INS insulation	

NOTE

All abbreviations in the parts list will be in upper-case.

Table 6-1. Reference Designations and Abbreviations (cont'd)

MOD modulator	OD outside diameter	PWV peak working voltage	TD time delay
MOM momentary	OH oval head	RC resistance-capacitance	TERM terminal
MOS metal-oxide semiconductor	OP AMPL operational amplifier	RECT rectifier	TFT thin-film transistor
ms millisecond	OPT option	REG regulated	TGL toggle
MTG mounting	OSC oscillator	REPL replaceable	THD thread
MTR meter (indicating device)	OX oxide	RF radio frequency	THRU through
mV millivolt	oz ounce	RFI radio frequency interference	TI titanium
mVac millivolt, ac	Ω ohm	RH round head; right hand	TOL tolerance
mVdc millivolt, dc	P peak (used in parts list)	RLC resistance-inductance-capacitance	TRIM trimmer
mVpk millivolt, peak	PAM pulse-amplitude modulation	RMO rack mount only	TSTR transistor-transistor logic
mVp-p millivolt, peak-to-peak	PC printed circuit	rms root-mean-square	TV television
mVrms millivolt, rms	PCM pulse-code modulation; pulse-count modulation	RND round	TVI television interference
mW milliwatt	PDM pulse-duration modulation	ROOM read-only memory	TWT traveling wave tube
MUX multiplex	pF picofarad	R&P rack and panel	U micro (10 ⁶) (used in parts list)
MY mylar	PH BRZ phosphor bronze	RWV reverse working voltage	UF microfarad (used in parts list)
μ A microampere	PHL Phillips	S scattering parameter	UHF ultrahigh frequency
μ F microfarad	PIN positive-intrinsic-negative	s second (time)	UNREG unregulated
μ H microhenry	PIV peak inverse voltage	" second (plane angle)	V volt
μ ho micromho	pk peak	S-B slow-blow (fuse) (used in parts list)	VA voltampere
μ s microsecond	PL phase lock	SCR silicon controlled rectifier; screw	Vac volts, ac
μ V microvolt	PLO phase lock oscillator	SE selenium	VAR variable
μ Vac microvolt, ac	PM phase modulation	SECT sections	VCO voltage-controlled oscillator
μ Vdc microvolt, dc	PNP positive-negative-positive	SEMICON semiconductor	Vde volts, dc
μ Vpk microvolt, peak	P/O part of	SHF superhigh frequency	VDCW volts, dc, working (used in parts list)
μ Vp-p microvolt, peak-to-peak	POLY polystyrene	SI silicon	V(F) volts, filtered
μ Vrms microvolt, rms	PORC porcelain	SIL silver	VFO variable-frequency oscillator
μ W microwatt	POS positive; position(s) (used in parts list)	SL slide	VHF very-high frequency
nA nanoampere	POSN position	SNR signal-to-noise ratio	Vpk volts, peak
NC no connection	POT potentiometer	SPDT single-pole, double-throw	Vp-p volts, peak-to-peak
NC/C normally closed	p-p peak-to-peak	SPG spring	Vrms volts, rms
NE neon	PP peak-to-peak (used in parts list)	SR split ring	VSWR voltage standing wave ratio
NEG negative	PPM pulse-position modulation	SPST single-pole, single-throw	VTO voltage-tuned oscillator
nF nanofarad	PREAMPL preamplifier	SSB single sideband	VTVM vacuum-tube voltmeter
NI PL nickel plate	PRF pulse-repetition frequency	SST stainless steel	V(X) volts, switched
N/O normally open	PRR pulse repetition rate	STL steel	W watt
NOM nominal	ps picosecond	SQ square	W/ with
NORM normal	PT point	SWR standing-wave ratio	WIV working inverse voltage
NPN negative-positive-negative	PTM pulse-time modulation	SYNC synchronize	WW wirewound
NPO negative-positive zero (zero temperature coefficient)	PWM pulse-width modulation	T timed (slow-blow fuse)	W/O without
NRFR not recommended for field replacement		TA tantalum	YIG yttrium-iron-garnet
NSR not separately replaceable		TC temperature compensating	Z ₀ characteristic impedance
ns nanosecond			
nW nanowatt			
OBD order by description			

NOTE

All abbreviations in the parts list will be in upper-case.

MULTIPLIERS

Abbreviation	Prefix	Multiple
T	tera	10 ¹²
G	giga	10 ⁹
M	mega	10 ⁶
k	kilo	10 ³
da	deka	10
d	deci	10 ⁻¹
c	centi	10 ⁻²
m	milli	10 ⁻³
μ	micro	10 ⁻⁶
n	nano	10 ⁻⁹
p	pico	10 ⁻¹²
f	femto	10 ⁻¹⁵
a	atto	10 ⁻¹⁸

Table 6-2. Replaceable Parts

Reference Designation	HP Part Number	Qty	Description	Mfr Code	Mfr Part Number
A1C8	0160-0575		CAPACITOR-FXD .047UF+-20% 100 VDC CER	28480	0160-0575
A1	08750-60004	1	BOARD ASSEMBLY, FRONT PANEL	28480	08750-60004
A1C1	0160-0575	13	CAPACITOR-FXD .047UF +-20% 100VDC CER	28480	0160-0575
A1C2	0160-3879	12	CAPACITOR-FXD .01UF +-20% 100VDC CER	28480	0160-3879
A1C3	0160-3879		CAPACITOR-FXD .01UF +-20% 100VDC CER	28480	0160-3879
A1C4	0160-4084	7	CAPACITOR-FXD .1UF +-20% 50VDC CER	28480	0160-4084
A1C5	0160-3879		CAPACITOR-FXD .01UF +-20% 100VDC CER	28480	0160-3879
A1C6	0180-0197		CAPACITOR-FXD 2.2UF +-20% 20VDC TA	04200	150D225X9020A2
A1C7	0160-4084		CAPACITOR-FXD .1UF +-20% 50VDC CER	28480	0160-4084
A1CR1	1901-0050	5	DIODE-SWITCHING 80V 200MA 2NS DO-7	28480	1901-0050
A1D81	1990-0487	11	LED-VISIBLE LUM-INT=1MCD IF=20MA=MAX	28480	1990-0487
A1D82	1990-0487		LED-VISIBLE LUM-INT=1MCD IF=20MA=MAX	28480	1990-0487
A1D83	1990-0487		LED-VISIBLE LUM-INT=1MCD IF=20MA=MAX	28480	1990-0487
A1D84	1990-0487		LED-VISIBLE LUM-INT=1MCD IF=20MA=MAX	28480	1990-0487
A1D85	1990-0487		LED-VISIBLE LUM-INT=1MCD IF=20MA=MAX	28480	1990-0487
A1D86	1990-0487		LED-VISIBLE LUM-INT=1MCD IF=20MA=MAX	28480	1990-0487
A1D87	1990-0487		LED-VISIBLE LUM-INT=1MCD IF=20MA=MAX	28480	1990-0487
A1D88	1990-0487		LED-VISIBLE LUM-INT=1MCD IF=20MA=MAX	28480	1990-0487
A1D89	1990-0487		LED-VISIBLE LUM-INT=1MCD IF=20MA=MAX	28480	1990-0487
A1D910	1990-0487		LED-VISIBLE LUM-INT=1MCD IF=20MA=MAX	28480	1990-0487
A1D911	1990-0487		LED-VISIBLE LUM-INT=1MCD IF=20MA=MAX	28480	1990-0487
A1Q1	1853-0034	6	TRANSISTOR PNP 8I TO-18 PD=360MW	28480	1853-0034
A1Q2	1854-0404	6	TRANSISTOR NPN 8I TO-18 PD=360MW	28480	1854-0404
A1Q3	1853-0034		TRANSISTOR PNP 8I TO-18 PD=360MW	28480	1853-0034
A1Q4	1854-0404		TRANSISTOR NPN 8I TO-18 PD=360MW	28480	1854-0404
A1R1	0698-3260	5	RESISTOR 464K 1% .125W F TC=0+-100	02995	MF4C=1
A1R2	0757-0458	5	RESISTOR 51.1K 1% .125W F TC=0+-100	03292	C4=1/8-T0=5112-F
A1R3	0698-3260		RESISTOR 464K 1% .125W F TC=0+-100	02995	MF4C=1
A1R4	2100-3637	4	RESISTOR-VAR CONTROL CP 20K 10% LIN	28480	2100-3637
A1R5	2100-3637		RESISTOR-VAR CONTROL CP 20K 10% LIN	28480	2100-3637
A1R6	2100-3637		RESISTOR-VAR CONTROL CP 20K 10% LIN	28480	2100-3637
A1R7	2100-3637		RESISTOR-VAR CONTROL CP 20K 10% LIN	28480	2100-3637
A1R8	0698-3449	2	RESISTOR 26.7K 1% .125W F TC=0+-100	03292	C4=1/8-T0=2872-F
A1R9	0698-3260		RESISTOR 464K 1% .125W F TC=0+-100	02995	MF4C=1
A1R10	0757-0290	1	RESISTOR 6.19K 1% .125W F TC=0+-100	02995	MF4C1/8-T0=6191-F
A1R11	0757-0442	22	RESISTOR 10K 1% .125W F TC=0+-100	03292	C4=1/8-T0=1002-F
A1R12	0698-3243	1	RESISTOR 178K 1% .125W F TC=0+-100	03292	C4=1/8-T0=1783-F
A1R13	0698-3440	3	RESISTOR 196 1% .125W F TC=0+-100	03292	C4=1/8-T0=196R-F
A1R14	0757-0438	13	RESISTOR 5.11K 1% .125W F TC=0+-100	03292	C4=1/8-T0=5111-F
A1R15	0698-3440		RESISTOR 196 1% .125W F TC=0+-100	03292	C4=1/8-T0=196R-F
A1R16	0698-3440		RESISTOR 196 1% .125W F TC=0+-100	03292	C4=1/8-T0=196R-F
A1R17	0757-0438		RESISTOR 5.11K 1% .125W F TC=0+-100	03292	C4=1/8-T0=5111-F
A1R20	0757-0442		RESISTOR 10K 1% .125W F TC=0+-100	03292	C4=1/8-T0=1002-F
A1R21	0698-3159	2	RESISTOR 26.1K 1% .125W F TC=0+-100	03292	C4=1/8-T0=2612-F
A1R22	0757-0458		RESISTOR 51.1K 1% .125W F TC=0+-100	03292	C4=1/8-T0=5112-F
A1R23	0757-0199	15	RESISTOR 21.5K 1% .125W F TC=0+-100	03292	C4=1/8-T0=2152-F
A1R24	0757-0442		RESISTOR 10K 1% .125W F TC=0+-100	03292	C4=1/8-T0=1002-F
A1R25	0698-3156	1	RESISTOR 14.7K 1% .125W F TC=0+-100	03292	C4=1/8-T0=1472-F
A1R26	0698-3132	2	RESISTOR 261 1% .125W F TC=0+-100	03292	C4=1/8-T0=2610-F
A1R27	0698-3132		RESISTOR 261 1% .125W F TC=0+-100	03292	C4=1/8-T0=2610-F
A1R28	0757-0199		RESISTOR 21.5K 1% .125W F TC=0+-100	03292	C4=1/8-T0=2152-F
A1R29	0757-0199		RESISTOR 21.5K 1% .125W F TC=0+-100	03292	C4=1/8-T0=2152-F
A1R30	0757-0438		RESISTOR 5.11K 1% .125W F TC=0+-100	03292	C4=1/8-T0=5111-F
A181	5060-9436	9	SWITCH, PC BOARD	28480	5060-9436
A182	5060-9436		SWITCH, PC BOARD	28480	5060-9436
A183	5060-9436		SWITCH, PC BOARD	28480	5060-9436
A184	5060-9436		SWITCH, PC BOARD	28480	5060-9436
A185	5060-9436		SWITCH, PC BOARD	28480	5060-9436
A186	5060-9436		SWITCH, PC BOARD	28480	5060-9436
A187	5060-9436		SWITCH, PC BOARD	28480	5060-9436
A188	5060-9436		SWITCH, PC BOARD	28480	5060-9436
A189	5060-9436		SWITCH, PC BOARD	28480	5060-9436
A1U1	1826-0037	1	IC, TRANSISTOR ARRAY, 2082A	04200	ULN2082A
A1U2	1816-1043	1	IC, ROM 37L810 PK	28480	1816-1043
A1U3	1810-0176	2	NETWORK-RES 8-PIN-8IP .15-PIN=8PCG	04200	203C4-CRR
A1U4	1820-1362	3	IC FF CMOS D-TYPE POS-EDGE-TRIG COM	03406	MM74C157N
A1U5	1820-1356	1	IC DCDR CMOS BIN 2-T0=4-LINE DUAL 2-INP	01921	CD4555BF
A1U6	1820-1356		IC GATE CMOS EXCL-OR QUAD 2-INP	01921	CD4030AF
A1U7	1810-0205	1	NETWORK-RES 8-PIN-8IP .15-PIN=8PCG	02483	750-81-R4,7K
A1U8	1820-1331	10	IC FF CMOS D-TYPE POS-EDGE-TRIG DUAL	01921	CD4013AF
A1U9	1820-1365	4	IC DBEL/MULTIPLXR CMOS 2-T0=1-LINE QUAD	03406	MM74C157N
A1U10	1820-1365		IC DBEL/MULTIPLXR CMOS 2-T0=1-LINE QUAD	03406	MM74C157N
A1U11	1820-1570	1	IC ENCDR CMOS 8-BIT	02037	MC14832CL
A1U12	1810-0045	1	NETWORK-RES 8-PIN-8IP .125-PIN=8PCG	02483	750
A1U13	1826-0092	6	IC OP AMP	28480	1826-0092

Table 6-2. Replaceable Parts

Reference Designation	HP Part Number	Qty	Description	Mfr Code	Mfr Part Number
A1 MISCELLANEOUS					
	2190-0067	4	WASHER-LX INYL T 1/4 IN .256-IN-ID	04805	1914-05
	2950-0072	4	NUT-MEX-DBL-CHAM 1/4-32-TMD .062-IN-TMK	28480	2950-0075
	3040-8823	4	KNOB, MINT GRAY	28480	3040-8823
A2	08750-60001	1	BOARD ASSEMBLY, ANALOG	28480	08750-60001
A2C1	0160-3877	3	CAPACITOR-FXD 100PF +-20% 200VDC CER	28480	0160-3877
A2C2	0160-2222	1	CAPACITOR-FXD 1500PF +-5% 300VDC	28480	0160-2222
A2C3	0160-3878	3	CAPACITOR-FXD 1000PF +-20% 100VDC CER	28480	0160-3878
A2C4	0180-0197	6	CAPACITOR-FXD 2.2UF+-10% 20VDC TA	04200	150D225X9020A2
A2C5	0180-2206	1	CAPACITOR-FXD 60UF+-10% 6VDC TA	04200	150D606X9006B2
A2C6	0180-0197		CAPACITOR-FXD 2.2UF+-10% 20VDC TA	04200	150D225X9020A2
A2C8	0160-0157	1	CAPACITOR-FXD 4700PF +-10% 200VDC POLYE	04200	292P47292
A2C9	0160-3879		CAPACITOR-FXD .01UF +-20% 100VDC CER	28480	0160-3879
A2C10	0160-3878		CAPACITOR-FXD 1000PF +-20% 100VDC CER	28480	0160-3878
A2C11	0160-3533	1	CAPACITOR-FXD 470PF +-5% 300VDC MICA0+70	28480	0160-3533
A2C12	0121-0445	1	CAPACITOR-V TRMR-CER 4.5-20PF 160V	01468	78-TRMR-16 4.5-20 PF, NY50
A2C13	0160-3874	1	CAPACITOR-FXD 10PF +-5% 300VDC	28480	0160-3874
A2C14	0180-0197		CAPACITOR-FXD 2.2UF+-10% 20VDC TA	04200	150D225X9020A2
A2C15	0180-0197		CAPACITOR-FXD 2.2UF +-10% 20VDC TA	04200	150D225X9020A2
A2C16	0160-0970	1	CAPACITOR-FXD .47UF +-10% 80VDC POLYE	28480	0160-0970
A2C17	0160-0154	1	CAPACITOR-FXD 2200PF +-10% 200VDC POLYE	04200	292P22292
A2C18	0180-0197		CAPACITOR-FXD 2.2UF+-10% 20VDC TA	04200	150D225X9020A2
A2C19	0180-0197		CAPACITOR-FXD 2.2UF+-10% 20VDC TA	04200	150D225X9020A2
A2C20	0180-0116	1	CAPACITOR-FXD 6.8UF+-10% 35VDC TA	04200	150D686X9035B2
A2C22	0160-3829	1	CAPACITOR-FXD .47UF +-10% 50VDC	28480	0160-3829
A2C26	0160-3879		CAPACITOR-FXD .01UF +-20% 100VDC CER	28480	0160-3879
A2C27	0160-2226	1	CAPACITOR-FXD 2200PF +-5% 300VDC	28480	0160-2226
A2C28	0160-4084		CAPACITOR-FXD .1UF +-20% 50VDC CER	28480	0160-4084
A2C30	0160-3879		CAPACITOR-FXD .01UF +-20% 100VDC CER	28480	0160-3879
A2C31	0160-3879		CAPACITOR-FXD .01UF +-20% 100VDC CER	28480	0160-3879
A2C32	0160-3879		CAPACITOR-FXD .01UF +-20% 100VDC CER	28480	0160-3879
A2C33	0160-3878		CAPACITOR-FXD 1000PF +-20% 100VDC CER	28480	0160-3878
A2CR1	1901-0050		DIODE-SWITCHING 80V 200MA 2N8 DO-7	28480	1901-0050
A2CR3	1901-0539	9	DIODE-SCHOTTKY	28480	1901-0539
A2CR4	1901-0539		DIODE-SCHOTTKY	28480	1901-0539
A2CR5	1901-0539		DIODE-SCHOTTKY	28480	1901-0539
A2CR6	1901-0539		DIODE-SCHOTTKY	28480	1901-0539
A2CR7	1901-0539		DIODE-SCHOTTKY	28480	1901-0539
A2CR8	1901-0376	1	DIODE-GEN PRP 35V 50MA DO-7	28480	1901-0376
A2CR9	1901-0539		DIODE-SCHOTTKY	28480	1901-0539
A2CR10	1901-0539		DIODE-SCHOTTKY	28480	1901-0539
A2CR11	1901-0539		DIODE-SCHOTTKY	28480	1901-0539
A2CR12	1901-0050		DIODE-SWITCHING 80V 200MA 2N8 DO-7	28480	1901-0050
A2L1	9140-0210	3	COIL-WLD 100UH 5% Q=50 .155DX.375LG	02172	15-1315-12J
A2L2	9140-0210		COIL-WLD 100UH 5% Q=50 .155DX.375LG	02172	15-1315-12J
A2L3	9140-0210		COIL-WLD 100UH 5% Q=50 .155DX.375LG	02172	15-1315-12J
A2Q1	1855-0417	1	TRANSISTOR J-FET N-CHAN D-MODE TO-18 SI	28480	1855-0417
A2Q2	1855-0241	2	TRANSISTOR MOSFET N-CHAN E-MODE TO-72 SI	02910	SD215
A2Q3	1853-0034		TRANSISTOR PNP SI TO-18 PD=360MW	28480	1853-0034
A2Q4	1854-0404		TRANSISTOR NPN SI TO-18 PD=360MW	28480	1854-0404
A2Q5	1854-0404		TRANSISTOR NPN SI TO-18 PD=360MW	28480	1854-0404
A2Q6	1853-0034		TRANSISTOR PNP SI TO-18 PD=360MW	28480	1853-0034
A2Q7	1855-0206	1	TRANSISTOR J-FET 2N4117 N-CHAN D-MODE	02883	2N4117
A2Q8	1854-0404		TRANSISTOR NPN SI TO-18 PD=360MW	28480	1854-0404
A2Q9	1855-0206		TRANSISTOR MOSFET N-CHAN E-MODE TO-72 SI	02910	SD215
A2R1	0757-0438		RESISTOR 5.11K 1% .125W P TC=0+-100	03292	C4-1/8-T0-5111-F
A2R2	0757-0442		RESISTOR 10K 1% .125W P TC=0+-100	03292	C4-1/8-T0-1002-F
A2R3	0698-0083	1	RESISTOR 147K 1% .125W P TC=0+-100	03292	C4-1/8-T0-1473-F
A2R5	0757-0416	2	RESISTOR 511 1% .125W P TC=0+-100	03292	C4-1/8-T0-511R-F
A2R6	0757-0442		RESISTOR 10K 1% .125W P TC=0+-100	03292	C4-1/8-T0-1002-F
A2R7	0757-0438		RESISTOR 5.11K 1% .125W P TC=0+-100	03292	C4-1/8-T0-5111-F
A2R8	0757-0280	7	RESISTOR 1K 1% .125W P TC=0+-100	03292	C4-1/8-T0-1001-F
A2R9	0757-0199		RESISTOR 21.5K 1% .125W P TC=0+-100	03292	C4-1/8-T0-2152-F
A2R10	0757-0438		RESISTOR 5.11K 1% .125W P TC=0+-100	03292	C4-1/8-T0-5111-F
A2R11	0757-0199		RESISTOR 21.5K 1% .125W P TC=0+-100	03292	C4-1/8-T0-2152-F
A2R12	0757-0442		RESISTOR 10K 1% .125W P TC=0+-100	03292	C4-1/8-T0-1002-F
A2R13	0698-0083	3	RESISTOR 1.96K 1% .125W P TC=0+-100	03292	C4-1/8-T0-1961-F
A2R14	0757-0460	1	RESISTOR 61.4K 1% .125W P TC=0+-100	03292	C4-1/8-T0-6192-F
A2R15	0757-0200	1	RESISTOR 3.62K 1% .125W P TC=0+-100	03292	C4-1/8-T0-5621-F
A2R16	0698-0084	2	RESISTOR 2.15K 1% .125W P TC=0+-100	03292	C4-1/8-T0-2151-F
A2R17	2100-2061	1	RESISTOR-TRMR 200 10% C TOP=ADJ 1-TRN	04568	62-204-1
A2R18	0698-3151	1	RESISTOR 2.87K 1% .125W P TC=0+-100	03292	C4-1/8-T0-2871-F
A2R19	2100-1986	1	RESISTOR-TRMR 1K 10% C TOP=ADJ 1-TRN	04568	62-206-1
A2R20	2100-1984	1	RESISTOR-TRMR 100 10% C TOP=ADJ 1-TRN	04568	62-203-1
A2R21	0698-0082	1	RESISTOR 464 1% .125W P TC=0+-100	03292	C4-1/8-T0-4640-F

Table 6-2. Replaceable Parts

Reference Designation	HP Part Number	Qty	Description	Mfr Code	Mfr Part Number	
A2R22	0757-0280	1	RESISTOR 1K 1% .125W F TC0+100	03292	C4-1/8-T0-1001-F	
A2R23	0757-0280		RESISTOR 1K 1% .125W F TC0+100	03292	C4-1/8-T0-1001-F	
A2R25	0757-0445		RESISTOR 100K 1% .125W F TC0+100	03292	C4-1/8-T0-1003-F	
A2R26	0757-0428		RESISTOR 1.62K 1% .125W F TC0+100	03292	C4-1/8-T0-1821-F	
A2R29	0757-0442		RESISTOR 10K 1% .125W F TC0+100	03292	C4-1/8-T0-1002-F	
A2R30	0757-0416	1	RESISTOR 511 1% .125W F TC0+100	03292	C4-1/8-T0-511A-F	
A2R31	0757-0199		RESISTOR 21.5K 1% .125W F TC0+100	03292	C4-1/8-T0-2152-F	
A2R32	0698-0084		RESISTOR 2.15K 1% .125W F TC0+100	03292	C4-1/8-T0-2151-F	
A2R33	0698-3150		RESISTOR 2.37K 1% .125W F TC0+100	03292	C4-1/8-T0-2371-F	
A2R34	0757-0420		RESISTOR 750 1% .125W F TC0+100	03292	C4-1/8-T0-751-F	
A2R35	0698-0083	2	RESISTOR 1.96K 1% .125W F TC0+100	03292	C4-1/8-T0-1961-F	
A2R36	0757-0420		RESISTOR 750 1% .125W F TC0+100	03292	C4-1/8-T0-751-F	
A2R37	0698-0083		RESISTOR 1.96K 1% .125W F TC0+100	03292	C4-1/8-T0-1961-F	
A2R38	0757-0438		RESISTOR 5.11K 1% .125W F TC0+100	03292	C4-1/8-T0-5111-F	
A2R39	0757-0445		RESISTOR 100K 1% .125W F TC0+100	03292	C4-1/8-T0-1003-F	
A2R40	0757-0199	1	RESISTOR 21.5K 1% .125W F TC0+100	03292	C4-1/8-T0-2152-F	
A2R41	0757-0442		RESISTOR 10K 1% .125W F TC0+100	03292	C4-1/8-T0-1002-F	
A2R42	0757-0436		RESISTOR 5.11K 1% .125W F TC0+100	03292	C4-1/8-T0-5111-F	
A2R43	0757-0436	1	RESISTOR 5.11K 1% .125W F TC0+100	03292	C4-1/8-T0-5111-F	
A2R44	0757-0430	3	RESISTOR 5.11K 1% .125W F TC0+100	03292	C4-1/8-T0-5111-F	
A2R45	0698-3457		RESISTOR 316K 1% .125W F TC0+100	02995	MP4C-1	
A2R46	2100-1966		RESISTOR-TRMR 1K 10% C TOP-ADJ 1-TRN	04566	62-206-1	
A2R47	0698-1055		RESISTOR 1M 5% .25W FC TC=800/+900	01607	CB1055	
A2R48	0698-3450		RESISTOR 42.2K 1% .125W F TC0+100	03292	C4-1/8-T0-4222-F	
A2R49	2100-1735	1	RESISTOR-TRMR 10K 10% C TOP-ADJ 1-TRN	04566	62-209-1	
A2R50	0757-0438		RESISTOR 5.11K 1% .125W F TC0+100	03292	C4-1/8-T0-5111-F	
A2R51	0757-0438		RESISTOR 5.11K 1% .125W F TC0+100	03292	C4-1/8-T0-5111-F	
A2R52	0757-0280		RESISTOR 1K 1% .125W F TC=0+100	03292	C4-1/8-T0-1001-F	
A2R53	0757-0438		RESISTOR 5.11K 1% .125W F TC=0+100	03292	MF4C-1	
A2R54	0757-0438	1	RESISTOR 5.11K 1% .125W F TC=0+100	03292	C4-1/8-T0-5111-F	
A2R55	0698-3457	2	RESISTOR 316K 1% .125W F TC0+100	02995	MP4C-1	
A2R56	0757-0442		RESISTOR 10K 1% .125W F TC0+100	03292	C4-1/8-T0-1002-F	
A2R57	0757-0199		RESISTOR 21.5K 1% .125W F TC0+100	03292	C4-1/8-T0-2152-F	
A2R58	0757-0442		RESISTOR 10K 1% .125W F TC=0+100	03292	C4-1/8-T0-1002-F	
A2R59	0757-0438		RESISTOR 5.11K 1% .125W F TC=0+100	03292	C4-1/8-T0-5111-F	
A2R60	0757-0421	2	RESISTOR 825 1% .125W F TC0+100	03292	C4-1/8-T0-825R-F	
A2R61	0757-0421		RESISTOR 825 1% .125W F TC0+100	03292	C4-1/8-T0-825R-F	
A2R62	0757-0280		RESISTOR 1K 1% .125W F TC0+100	03292	C4-1/8-T0-1001-F	
A2R63	0698-3608		RESISTOR 4K 1% .125W F TC0+100	03292	C4-1/8-T0-4001-F	
A2R64	0757-0280		RESISTOR 1K 1% .125W F TC=0+100	03292	C4-1/8-T0-1001-F	
A2R65	0698-5808	1	RESISTOR 4K 1% .125W F TC=0+100	03292	C4-1/8-T0-4001-F	
A2R66	0757-0442	1	RESISTOR 10K 1% .125W F TC=0+100	03292	C4-1/8-T0-1002-F	
A2R67	0757-0401	1	RESISTOR 100 1% .125W F TC=0+100	03292	C4-1/8-T0-1000-F	
A2R68	0757-0199	1	RESISTOR 21.5K 1% .125W F TC=0+100	03292	C4-1/8-T0-2152-F	
A2TP1	1251-0600	8	CONTACT-CONN Q/W-POST-TYPE MALE DPSLDR	28480	1251-0600	
A2TP2	1251-0600		CONTACT-CONN U/W-POST-TYPE MALE DPSLDR	28480	1251-0600	
A2TP3	1251-0600		CONTACT-CONN U/W-POST-TYPE MALE DPSLDR	28480	1251-0600	
A2TP4	1251-0600		CONTACT-CONN U/W-POST-TYPE MALE DPSLDR	28480	1251-0600	
A2TP5	1251-0600		CONTACT-CONN U/W-POST-TYPE MALE DPSLDR	28480	1251-0600	
A2TP6	1251-0600		CONTACT-CONN U/W-POST-TYPE MALE DPSLDR	28480	1251-0600	
A2TP7	1251-0600		CONTACT-CONN U/W-POST-TYPE MALE DPSLDR	28480	1251-0600	
A2TP8	1251-0600		CONTACT-CONN U/W-POST-TYPE MALE DPSLDR	28480	1251-0600	
A2U1	1820-1531		2	IC FF CMOS D-TYPE POS-EDGE-TRIG DUAL	01921	CD4013AF
A2U2	1820-1112			IC FF TTL LS D-TYPE POS-EDGE-TRIG	01698	SN74LS74N
A2U3	1820-1569			IC DUAL MONOSTABLE MV	28480	1820-1569
A2U4	1820-1212			IC FF TTL LS J-K NEG-EDGE-TRIG	01698	SN74LS112N
A2U5	1826-0026		3	IC COMPARATOR	03406	LM311H
A2U6	1826-0081		1	IC 318 OP AMP	03406	LM318H
A2U7	1820-1538		3	IC GATE CMOS NAND QUAD 2-INP	01921	CD4011AF
A2U8	1820-1484		1	IC BFR CMOS INV HEX 1-INP	02237	40098PC
A2U9	1820-1425	1	IC SCHMITT-TRIG TTL LS NAND QUAD 2-INP	01698	SN74LS132N	
A2U10	1820-1144	1	IC GATE TTL LS NOR QUAD 2-INP	01698	SN74LS02N	
A2U11	1820-1197	1	IC GATE TTL LS NAND QUAD 2-INP	01698	SN74LS00N	
A2U12	1820-1531	1	IC FF CMOS D-TYPE POS-EDGE-TRIG DUAL	01921	CD4013AF	
A2U13	1820-1935	1	IC RGTR CMOS 12-BIT	03406	MM74C905J	
A2U14	1820-1195	4	IC FF TTL LS D-TYPE POS-EDGE-TRIG COM	01698	SN74LS175N	
A2U15	1820-1195	2	IC FF TTL LS D-TYPE POS-EDGE-TRIG COM	01698	SN74LS175N	
A2U16	1820-1934		IC CONV D/A 8-BIT	02180	DAC-08EQ	
A2U17	1820-1941		IC SW ANALOG	03406	LF13201N	
A2U18	1826-0026		IC COMPARATOR	03406	LM311H	
A2U19	1826-0127	1	IC CONV TTL* D/A 10-BIT	02180	DAC100BCQ3	
A2U20	1820-1195	1	IC FF TTL LS D-TYPE POS-EDGE-TRIG COM	01698	SN74LS175N	
A2U21	1820-1195		IC FF TTL LS D-TYPE POS-EDGE-TRIG COM	01698	SN74LS175N	
A2U22	1820-1934		IC CONV D/A 8-BIT	02180	DAC-08EQ	
A2U23	1826-0026		IC COMPARATOR	03406	LM311H	
A2U24	1813-0041		1	IC OP AMP	03406	LM8042CH
A2U25	1820-1545		1	IC DSEL/MULTIPLXR CMOS TPL	02037	MC14053BCL
A2U26	1826-0319		3	IC OP AMP	03406	LF356H
A2U27	1820-1544			IC FF CMOS D-TYPE POS-EDGE-TRIG COM	01921	CD4076AF
A2U28	1820-1544			IC FF CMOS D-TYPE POS-EDGE-TRIG COM	01921	CD4076AF
A2U29	1820-1211			2	IC GATE TTL LS EXCL-OR QUAD 2-INP	01698
A2U30	1820-1211	IC GATE TTL LS EXCL-OR QUAD 2-INP	01698		SN74LS86N	

Table 6-2. Replaceable Parts

Reference Designation	HP Part Number	Qty	Description	Mfr Code	Mfr Part Number
A2U31	1820-1112		IC FF TTL L8 D-TYPE POS-EDGE-TRIG	01698	8N74L874N
A2U32	1820-1545		IC DSEL/MULTIPLXR CMOS TPL	02037	MC140538CL
A2U33	1826-0319		IC OP AMP	03406	LF356H
A2U34	1826-0319		IC OP AMP	03406	LF356H
A2U35	1820-1545		IC DSEL/MULTIPLXR CMOS TPL	02037	MC140538CL
A2U36	1826-0319	6	IC OP AMP	03406	LF356H
A2U37	1826-0319		IC OP AMP	03406	LF356H
A2U38	1820-1544		IC FF CMOS D-TYPE POS-EDGE-TRIG COM	01921	CD4076AF
A2U39	1826-0261	1	IC 741 OP AMP	28480	1826-0261
A2U40	1826-0319		IC OP AMP	03406	LF356H
A2VR1	1902-3005	1	DIODE-ZNR 2.43V 5% DO-7 PD=.4W TC=-.076K	02037	82 10019-5
A2VR2	1902-0041	1	DIODE-ZNR 5.11V 5% DO-7 PD=.4W TC=-.009K	02763	CD 35622
A3	08750-60002	1	BOARD ASSEMBLY, DIGITAL	28480	08750-60002
A3C1	0160-3402	1	CAPACITOR-FXD 1UF +-5% 50VDC MET-POLYC	28480	0160-3402
A3C2	0160-0575	1	CAPACITOR-FXD .047UF +-20% 50VDC	28480	0160-0575
A3C3	0160-3877		CAPACITOR-FXD 100PF +-20% 200VDC CER	28480	0160-3877
A3C4	0160-3877		CAPACITOR-FXD 100PF +-20% 200VDC CER	28480	0160-3877
A3C5	0180-0229	1	CAPACITOR-FXD 33UF+-10% 10VDC TA	04200	1500336X901082
A3C6	0160-3879		CAPACITOR-FXD .01UF +-20% 100VDC CER	28480	0160-3879
A3C7	0160-3879		CAPACITOR-FXD .01UF +-20% 100VDC CER	28480	0160-3879
A3C8	0160-3879		CAPACITOR-FXD .01UF +-20% 100VDC CER	28480	0160-3879
A3C9	0160-3879		CAPACITOR-FXD .01UF +-20% 100VDC CER	28480	0160-3879
A3C10	0160-3879		CAPACITOR-FXD .01UF +-20% 100VDC CER	28480	0160-3879
A3C11	0160-3879		CAPACITOR-FXD .01UF +-20% 100VDC CER	28480	0160-3879
A3C12	0160-3878		CAPACITOR-FXD 1000PF +-20% 200VDC CER	28480	0160-3878
A3J1	1251-4008	1	CONNECTOR 8-PIN M POSTY TYPE	28480	1251-4008
A3R1	0683-1555	1	RESISTOR 1.5K 5% .25W PC TC=900/+1100	01607	CB1555
A3R2	0757-0123	1	RESISTOR 34.8K 1% .125W F TC=0/+100	02273	CEA-993
A3R3	0757-0199		RESISTOR 21.5K 1% .125W F TC=0/+100	03292	C4=1/8-T0-2152-F
A3R5	0757-0442		RESISTOR 10K 1% .125W F TC=0/+100	03292	C4=1/8-T0-1002-F
A3R6	0757-0199		RESISTOR 21.5K 1% .125W F TC=0/+100	03292	C4=1/8-T0-2152-F
A3R7	0757-0199		RESISTOR 21.5K 1% .125W F TC=0/+100	03292	C4=1/8-T0-2152-F
A3R9	0757-0465		RESISTOR 100K 1% .125W F TC=0/+100	03292	C4=1/8-T0-1003-F
A3R10	0698-3260		RESISTOR 464K 1% .125W F TC=0/+100	02095	MF4C-1
A3R11	0757-0438		RESISTOR 5.11K 1% .125W F TC=0/+100	03292	C4=1/8-T0-5111-F
A3R12	0757-0438		RESISTOR 5.11K 1% .125W F TC=0/+100	03292	C4=1/8-T0-5111-F
A3R13	0757-0442		RESISTOR 10K 1% .125W F TC=0/+100	03292	C4=1/8-T0-1002-F
A3R14	0757-0458		RESISTOR 5.11K 1% .125W F TC=0/+100	03292	C4=1/8-T0-0111-F
A3U1	1818-0322	12	IC 91L12 1K RAM MOS	03794	AM91L12APC
A3U2	1818-0322		IC 91L12 1K RAM MOS	03794	AM91L12APC
A3U3	1818-0322		IC 91L12 1K RAM MOS	03794	AM91L12APC
A3U4	1820-1365		IC DSEL/MULTIPLXR CMOS 2-TO-1-LINE QUAD	03406	MM74C157N
A3U5	1820-1150	2	IC CNTR CMOS BIN SYNCHRO DUAL 4-BIT	02037	MC14540CP
A3U6	1818-0322		IC 91L12 1K RAM MOS	03794	AM91L12APC
A3U7	1818-0322		IC 91L12 1K RAM MOS	03794	AM91L12APC
A3U8	1818-0322		IC 91L12 1K RAM MOS	03794	AM91L12APC
A3U9	1818-0322		IC 91L12 1K RAM MOS	03794	AM91L12APC
A3U10	1818-0322		IC 91L12 1K RAM MOS	03794	AM91L12APC
A3U11	1818-0322		IC 91L12 1K RAM MOS	03794	AM91L12APC
A3U12	1818-0322		IC 91L12 1K RAM MOS	03794	AM91L12APC
A3U13	1818-0322		IC 91L12 1K RAM MOS	03794	AM91L12APC
A3U14	1818-0322		IC 91L12 1K RAM MOS	03794	AM91L12APC
A3U15	1820-1365		IC DSEL/MULTIPLXR CMOS 2-TO-1-LINE QUAD	03406	MM74C157N
A3U16	1820-1150		IC CNTR CMOS BIN SYNCHRO DUAL 4-BIT	02037	MC14520CP
A3U17	1820-1937	3	IC ADDR CMOS BIN FULL ADDR 4-BIT	03406	MM74C83J
A3U18	1820-1531		IC FF CMOS D-TYPE POS-EDGE-TRIG DUAL	01921	CD4013AF
A3U19	1820-1531		IC GATE CMOS NAND QUAD 2-INP	01921	CD4011AF
A3U20	1820-1531		IC FF CMOS D-TYPE POS-EDGE-TRIG DUAL	01921	CD4013AF
A3U21	1820-1934	1	IC GATE CMOS NOR QUAD 2-INP	01921	CD4001AF
A3U22	1820-1266	2	IC BFR CMOS NON-INV HEX 1-INP	03406	MM80C97N
A3U23	1820-1937		IC ADDR CMOS BIN FULL ADDR 4-BIT	03406	MM74C83J
A3U24	1820-1562		IC FF CMOS D-TYPE POS-EDGE-TRIG COM	03406	MM74C175N
A3U25	1820-1936	1	IC SCHMITT-TRIG CMOS NAND QUAD 2-INP	02037	MC140938CL
A3U26	1820-1531		IC FF CMOS D-TYPE POS-EDGE-TRIG DUAL	01921	CD4013AF
A3U27	1820-1532	2	IC GATE CMOS NAND TPL 3-INP	01921	CD4023BF
A3U28	1820-1535	1	IC GATE CMOS NOR TPL 3-INP	01921	CD4025BF
A3U29	1820-1842	1	IC BFR CMOS INV HEX 1-INP	01921	CD4049BF
A3U30	1820-1933	1	IC FF CMOS D-TYPE POS-EDGE-TRIG	03406	MM74C74J
A3U31	1820-1531		IC FF CMOS D-TYPE POS-EDGE-TRIG DUAL	01921	CD4013AF
A3U32	1820-1266		IC BFR CMOS NON-INV HEX 1-INP	03406	MM80C97N
A3U33	1820-1937		IC ADDR CMOS BIN FULL ADDR 4-BIT	03406	MM74C83J
A3U34	1820-1562		IC FF CMOS D-TYPE POS-EDGE-TRIG COM	03406	MM74C175N
A3U35	1820-1531		IC FF CMOS D-TYPE POS-EDGE-TRIG DUAL	01921	CD4013AF
A3U36	1820-1531		IC FF CMOS D-TYPE POS-EDGE-TRIG DUAL	01921	CD4013AF
A3U37	1820-1536		IC GATE CMOS NAND QUAD 2-INP	01921	CD4023BF
A3U38	1820-1852		IC GATE CMOS NAND TPL 3-INP	01921	CD4025BF
A3U39	1820-1569	1	IC MV CMOS MONOSTBL RETRIG/RESEY DUAL	02037	MC145385CL
A3U40	1816-1042	1	IC, ROM 27L810 PIK	28480	1816-1042

Table 6-2. Replaceable Parts

Reference Designation	HP Part Number	Qty	Description	Mfr Code	Mfr Part Number
A3U1 A3U2 A3U3	1620-1531 1610-0176 1610-0050	1	IC FF CMOS D-TYPE POS-EDGE-TRIG DUAL NETWORK=RES 5-PIN=81P ,15-PIN=8PCG NETWORK=RES 12-PIN=81P ,15-PIN=8PCG	01921 04200 28480	C04013AF 203C4-CRR 1610-0050
A4	06750-60003	1	MOTHERBOARD ASSEMBLY	28480	06750-60003
A4C1 A4C2 A4C3 A4C4 A4C5	0160-2501 0160-2501 0160-2500 0160-2500 0160-4084	2	CAPACITOR=FXD 680UF+50-10X 25VDC AL CAPACITOR=FXD 680UF+50-10X 25VDC AL CAPACITOR=FXD 1500UF+50-10X 16VDC AL CAPACITOR=FXD 1500UF+50-10X 16VDC AL CAPACITOR=FXD .1UF +/-20% 50VDC CER	28480 28480 03856 03856 28480	0160-2501 0160-2501 77152U01661C3P 77152U01661C3P 0160-4084
A4CR1 A4CR2 A4CR3 A4CR4	1901-0050 1901-0159 1901-0159 1901-0364	2	DIODE-SWITCHING 80V 200MA 2NS DO-7 DIODE-PHR RECT 400V 750MA DO-41 DIODE-PHR RECT 400V 750MA DO-41 DIODE-FW BRDG 200V 1A	28480 02037 02037 02037	1901-0050 8R1358-4 8R1358-4 8DA 10185-4
A4J2 A4J5	1200-0507 1251-3976	1	SOCKET-IC 16-CONY DIP-8LDR CONNECTOR 6-PIN M POST TYPE	02194 03418	ICN-163-83M 22-03-1061
A4MP1 A4MP2	1200-0185 1205-0061	1	INSULATOR-X8TR NYLON HEAT SINK TO-5/TO-39-PKG	02608 28480	7717-86N RED 1205-0061
A4J1 A4J3 A4J4	1251-4049 1251-4822 1251-4822	1	CONNECTOR 15-PIN M POST TYPE CONNECTOR 3-PIN M POST TYPE CONNECTOR 3-PIN M POST TYPE	03418 03418 03418	22-03-2151 22-03-2031 22-03-2031
A4Q1 A4Q2	1854-0022 1853-0034	1	TRANSISTOR NPN 8I TO-39 PD=700MW TRANSISTOR PNP 8I TO-18 PD=360MW	02237 28480	817843 1853-0034
A4R1 A4R2	0757-0456 0757-1094	1	RESISTOR 51.1K 1% .125W F TC=0+-100 RESISTOR 1.47K 1% .125W F TC=0+-100	03292 03292	C4-1/8-TO-5112-F C4-1/8-TO-1471-F
A4TP1 A4TP2 A4TP3	1251-0600 1251-0600 1251-0600	1	CONTACT-CONN U/W-POST-TYPE MALE DP8LDR CONTACT-CONN U/W-POST-TYPE MALE DP8LDR CONTACT-CONN U/W-POST-TYPE MALE DP8LDR	28480 28480 28480	1251-0600 1251-0600 1251-0600
A4U1	1826-0178	1	IC V RGLTR	03406	LMS20M-12
A4XA2 A4XA3 A4XA5	1251-2582 1251-1365 1251-2916	1	CONNECTOR-PC EDGE 24-CONY/ROW 2-ROWS CONNECTOR-PC EDGE 22-CONY/ROW 2-ROWS CONNECTOR-PC EDGE 18-CONY/ROW 2-ROWS	04907 04907 02107	252-24-30-300 252-22-30-300 3VH16/1JE12
A5	06750-60009	1	BOARD ASSY, SPECTRUM ANALYZER INTERFACE	28480	06750-60009
A5 C1 A5 C2 A5 C3 A5 C4	0160-4084 0160-4084 0160-2237 0160-2244	1	CAPACITOR=FXD .1UF +/-20% 50VDC CER CAPACITOR=FXD .1UF +/-20% 50VDC CER CAPACITOR=FXD 1.2PF +/-25PF 500VDC CAPACITOR=FXD 3PF +/-25PF 500VDC	28480 28480 28480 28480	0160-4084 0160-4084 0160-2237 0160-2244
A5 CR1	1901-0050	1	DIODE-SWITCHING 80V 200MA 2NS DO-7	28480	1901-0050
A5 Q1 A5 Q2	1853-0034 1854-0404	1	TRANSISTOR PNP 8I TO-18 PD=360MW TRANSISTOR NPN 8I TO-18 PD=360MW	28480 28480	1853-0034 1854-0404
A5 R1 A5 R2 A5 R3 A5 R4 A5 R5	2100-2514 2100-2522 2100-2514 2100-2522 0757-0461	6	RESISTOR-TRMR 20K 10% C SIDE-ADJ 1-TRN RESISTOR-TRMR 10K 10% C SIDE-ADJ 1-TRN RESISTOR-TRMR 20K 10% C SIDE-ADJ 1-TRN RESISTOR-TRMR 10K 10% C SIDE-ADJ 1-TRN RESISTOR 68.1K 1% .125W F TC=0+-100	04568 04568 04568 04568 03292	62-226-1 62-227-1 62-228-1 62-227-1 C4-2/8-TO-6812-F
A5 R6 A5 R7 A5 R8 A5 R9 A5 R10	0698-3460 0757-0447 0757-0459 0757-0442 0683-6845	1	RESISTOR 422K 1% .125W F TC=0+-100 RESISTOR 16.2K 1% .125W F TC=0+-100 RESISTOR 56.2K 1% .125W F TC=0+-100 RESISTOR 10K 1% .125W F TC=0+-100 RESISTOR 680K 5% .25W FC TC=-800/+900	28480 03292 03292 03292 28480	0698-3460 C4-1/8-TO-1622-F C4-1/8-TO-5622-F C4-1/8-TO-1002-F 0683-6845
A5 R11 A5 R12 A5 R13 A5 R14 A5 R15	0698-3449 0757-0442 0757-0482 0757-0442 0757-0462	1	RESISTOR 28.7K 1% .125W F TC=0+-100 RESISTOR 10K 1% .125W F TC=0+-100 RESISTOR 511K 5% .25W FC TC=-800/+900 RESISTOR 10K 1% .125W F TC=0+-100 RESISTOR 75K 1% .125W F TC=0+-100	03292 03292 28480 03292 03292	C4-1/8-TO-2872-F C4-1/8-TO-1002-F 0757-0482 C4-1/8-TO-1002-F C4-1/8-TO-7502-F
A5 R16 A5 R17 A5 R18 A5 R19 A5 R20	0757-0442 0757-0458 0757-0199 0757-0199 0757-0289	1	RESISTOR 10K 1% .125W F TC=0+-100 RESISTOR 51.1K 1% .125W F TC=0+-100 RESISTOR 21.5K 1% .125W F TC=0+-100 RESISTOR 21.5K 1% .125W F TC=0+-100 RESISTOR 13.3K	03292 03292 03292 03292 03292	C4-1/8-TO-1002-F C4-1/8-TO-5112-F C4-1/8-TO-2152-F C4-1/8-TO-2152-F C4-1/8-TO-1332-F
A5 R21 A5 R22 A5 R23	0757-0442 0757-0442 0698-3457	1	RESISTOR 10K 1% .125W F TC=0+-100 RESISTOR 10K 1% .125W F TC=0+-100 RESISTOR 316K 1% .125W F TC=0+-100	03292 03292 02995	C4-1/8-TO-1002-F C4-1/8-TO-1002-F MF4C-1
A5 S1	3101-1273	3	SWITCH-8L OPOT-NS SUBMIN 2A 120VAC RC	28480	3101-1273
A5 U1 A5 U2 A5 U3 A5 U4	1826-0092 1826-0316 1826-0092 1826-0316	2	IC OP AMP IC REF AMPL IC OP AMP IC REF AMPL	28480 03406 28480 03406	1826-0092 LM0070-1M 1826-0092 LM0070-1M

Table 6-2. Replaceable Parts

Reference Designation	HP Part Number	Qty	Description	Mfr Code	Mfr Part Number
A5	08750-60005	1	BOARD ASSY, NETWORK ANALYZER INTERFACE	28480	08750-60005
ASC1	0160-4084		CAPACITOR-PXD .1UF +-20% 50VDC CER	28480	0160-4084
ASC2	0160-4084		CAPACITOR-PXD .1UF +-20% 50VDC CER	28480	0160-4084
ASQ1	1854-0019	1	TRANSISTOR NPN 8T TO-18 PD=360MW	28480	1854-0019
ASR1	0757-0442	2	RESISTOR 11K 1% .125W F TC=0+-100	02995	MF4C1/8-TO-1102-F
ASR2	0757-0467	2	RESISTOR 121K 1% .125W F TC=0+-100	03292	C4-1/8-TO-1213-F
ASR3	0757-0442		RESISTOR 11K 1% .125W F TC=0+-100	02995	MF4C1/8-TO-1102-F
ASR4	0757-0467		RESISTOR 121K 1% .125W F TC=0+-100	03292	C4-1/8-TO-1213-F
ASR5	2100-2514		RESISTOR-TRMR 20K 10% C SIDE-ADJ 1-TRN	04568	62-228-1
ASR6	0757-0466	1	RESISTOR 110K 1% .125W F TC=0+-100	03292	C4-1/8-TO-1103-F
ASR7	0757-0438	1	RESISTOR-TRMR 5.11K 1% .125W F TC=0+-100	03292	C4-1/8-TO-5112-F
ASR8	2100-2517		RESISTOR-TRMP 100K 10% C SIDE-ADJ 1-TRN	28480	2100-2517
ASR9	0757-0447		RESISTOR 100K 1% .125W F TC=0+-100	03292	C4-1/8-TO-1003-F
ASR10	0757-0447	1	RESISTOR 16.2K 1% .125W F TC=0+-100	03292	C4-1/8-TO-1622-F
ASR11	2100-2517		RESISTOR-TRMR 50K 10% C SIDE-ADJ 1-TRN	28480	2100-2517
ASR12	2100-2514		RESISTOR-TRMR 20K 10% C SIDE-ADJ 1-TRN	04568	62-228-1
ASR13	0698-3155	1	RESISTOR 261K 1% .125W F TC=0+-100	03292	C4-1/8-TO-2613-F
ASR14	0757-0442		RESISTOR 10K 1% .125W F TC=0+-100	03292	C4-1/8-TO-1002-F
ASR15	0757-0442		RESISTOR 10K 1% .125W F TC=0+-100	03292	C4-1/8-TO-1002-F
ASR16	0757-0199		RESISTOR 21.5K 1% .125W F TC=0+-100	03292	C4-1/8-TO-2152-F
ASR17	0757-0199		RESISTOR 21.5K 1% .125W F TC=0+-100	03292	C4-1/8-TO-2152-F
ASR19	0698-3152		RESISTOR 46.4K 1% .125W F TC=0+-100	03292	C4-1/8-TO-4642-F
ASR20	0757-0442		RESISTOR 10K 1% .125W F TC=0+-100	03292	C4-1/8-TO-1002-F
ASR21	0698-3156	1	RESISTOR 14.7K 1% .125W F TC=0+-100	03292	C4-1/8-TO-1472-F
ASR22	0757-0442		RESISTOR 10K 1% .125W F TC=0+-100	03292	C4-1/8-TO-1002-F
ASR23	0757-0442		RESISTOR 10K 1% .125W F TC=0+-100	03292	C4-1/8-TO-1002-F
ASR24	0757-0442		RESISTOR 10K 1% .125W F TC=0+-100	03292	C4-1/8-TO-1002-F
ASQ1	3101-1273		SWITCH-8L DPDT-N8 SUBMIN 2A 120VAC PC	28480	3101-1273
ASQ2	3101-1273		SWITCH-8L DPDT-N8 SUBMIN 2A 120VAC PC	28480	3101-1273
ASU1	1826-0092		IC OP AMP	28480	1826-0092
ASU2	1826-0092		IC OP AMP	28480	1826-0092
ASU3	1820-1948	1	IC 8W PMOS ANALOG	01698	7L607CP
ASU4	1826-0092		IC OP AMP	28480	1826-0092
MODEL 8750A STORAGE-NORMALIZER REPL. PYS					
J1	1250-0083	3	CONNECTOR-RF BNC FEM SGL-HOLE-FR TO-OHM	03316	28JR-130-1
J2	1250-0083		CONNECTOR-RF BNC FEM SGL-HOLE-FR 50-OHM	03316	28JR-130-1
J3	1250-0083		CONNECTOR-RF BNC FEM SGL-HOLE-FR 50-OHM	03316	28JR-130-1
J4	1251-2197		CONNECTOR 24-PIN F D SERIES	04486	DDM-24W7S
S1	3101-1609	1	SWITCH-8L 2-DPDT-N8 STD 1.5A 250VAC	05057	11E-1036
Y1	9100-3962	1		28480	9100-3962
U1	1826-0147	1	IC 7812 V RGLTR, +12V	02037	MC7812CP
U2	1826-0122	1	IC 7805 V RGLTR, +5V	02237	7805UC
W1	08750-60010	1	CABLE ASSEMBLY, POWER	28480	08750-60010
W1S1	3101-2025	1	SWITCH, ROCKER DPDT	28480	3101-2025
W2	08750-60006	1	CABLE ASSEMBLY, DIGITAL INTERFACE	28480	08750-60006
W3	08750-60007	1	CABLE ASSEMBLY, ANALOG INTERFACE	28480	08750-60007
W4	08750-60013	2	CABLE ASSEMBLY, REGULATOR	28480	08750-60013
W5	08750-60013		CABLE ASSEMBLY, REGULATOR	28480	08750-60013
W6	08750-60012	5	CABLE ASSEMBLY, COAXIAL	28480	08750-60012
W7	08750-60012		CABLE ASSEMBLY, COAXIAL	28480	08750-60012
W8	08750-60012		CABLE ASSEMBLY, COAXIAL	28480	08750-60012
W9	08750-60012		CABLE ASSEMBLY, COAXIAL	28480	08750-60012
W10	08750-60012		CABLE ASSEMBLY, COAXIAL	28480	08750-60012
W11	08750-60011	1	CABLE ASSEMBLY, REAR PANEL OUTPUT	28480	08750-60011
	08750-60008	1	CABLE ASSEMBLY, NORMALIZER INTERCONNECT	28480	08750-60008

Table 6-2. Replaceable Parts

Reference Designation	HP Part Number	Qty	Description	Mfr Code	Mfr Part Number
CABINET PARTS					
1	5020-8813		FRONT FRAME	28480	5020-8813
2	5001-0438		SIDE TRIM	28480	5001-0438
3	5040-7201		BOTTOM FOOT	28480	5040-7201
4	08750-00009		FOOT	28480	08750-00009
5	5040-7203		TOP TRIM STRIP	28480	5040-7203
6	5040-7208		TOP COVER	28480	5040-7208
7	5040-7209		BOTTOM COVER	28480	5040-7209
8	5040-7212		SIDE COVER	28480	5040-7212
9	08750-00001		FRONT PANEL	28480	08750-00001
10	08750-00002		FRONT SUB-PANEL	28480	08750-00002
11	08750-00003		REAR PANEL	28480	08750-00003
12	08750-00004		DECK	28480	08750-00004
MISCELLANEOUS MECHANICAL PARTS					
	2950-0001	3	NUT-HEX-DBL-CHAM 3/8-32-THD .094-IN-THK	28480	2950-0002
	3050-0105	1	WASHER-FL MTLG NO. 4 .125-IN-ID	28480	3050-0106
	7120-1254	1	NAMEPLATE .312-IN-WD .54-IN-LG AL	28480	7120-1254
	5040-0352	2	PUSHBUTTON KEY, "LED"	28480	5040-0352
	5041-0809	1	PUSHBUTTON KEY, "HOLD"	28480	5041-0809
	5041-0810	1	PUSHBUTTON KEY, "RECALL"	28480	5041-0810
	5041-0821	1	PUSHBUTTON KEY, "INPUT"	28480	5041-0821
	5041-0822	1	PUSHBUTTON KEY, "INPUT MANUAL"	28480	5041-0822
	5041-0823	1	PUSHBUTTON KEY, "STORE IN"	28480	5041-0823
	5041-0824	1	PUSHBUTTON KEY, "BYPASS"	28480	5041-0824
	5041-0825	1	PUSHBUTTON KEY, "X/Y PLOT"	28480	5041-0825
	08750-00007	1	BRACKET, PLATFORM	28480	08750-00007
	08750-00008	1	BRACKET, PLATFORM	28480	08750-00008
	08750-00010	1	BRACKET, PC BD, STORAGE	28480	08750-00010
	0360-0009	1	TERMINAL-BLDR LUG PL-MTG PDR-#6-8CR	04604	1912
	0380-0020	2	SPACER-RND .25LG .128ID .188OD BR8 NI-PL	04757	3-5165-174
	0403-0026	2	GLIDE NYLON	28480	0403-0026
	08750-20015	2	MOUNTING BLOCK	28480	08750-20015
	0610-0001	2	NUT-HEX-DBL-CHAM 2-56-THD .062-IN-THK	28480	0610-0002
	1251-2942	2	LOCK-SUBMIN D CONN	28480	1251-2942
	1251-2197	2	CONNECTOR 24-PIN F D SERIES	04466	DDM-24W73
	1251-3973	1	CONNECTOR 6-PIN F POST TYPE	03418	22-01-1061
	1251-4052	5	CONTACT-CONN U/N-POST-TYPE FEM CRP	28480	1251-4052
	1400-0053	1	CLAMP-CA .172-DIA .375-WD NYL	05683	HC-34NA
	1400-0249	3	CABLE TIE .062-.625-DIA .091-WD NYL	02826	08474 BOX PACKAGE
	1460-1345	2	TILT STAND SST	28480	1460-1345
	2110-0465	1	FUSEHOLDER-EXTR POST UL/IEC .25X1.25/FUSE	28480	2110-0465
	2110-0467	1	NUT, HEX SINGLE CHAMFER 1/2-28 THREAD	75915	903-070
	2110-0470	1	FUSEHOLDER-EXTR POST 20A 300V UL/IEC	04703	345003-010
	2190-0004	2	WASHER-LK INTL T NO. 6 .115-IN-ID	02440	418-8C EVERLOCK WASHER
	2190-0014	2	WASHER-LK INTL T NO. 2 .089-IN-ID	04605	1902-00
	2190-0016	3	WASHER-LK INTL T 3/8 IN .377-IN-ID	28480	2190-0016
	2190-0037	1	WASHER-LK INTL T 1/2 IN .512-IN-ID	04605	1224-08
	2200-0103	7	SCREW-MACH 4-40 .25-IN-LG PAN-HD-POZI	28480	2200-0103
	2200-0121	2	SCREW-MACH 4-40 1.125-IN-LG PAN-HD-POZI	28480	2200-0121
	2360-0113	4	SCREW-MACH 6-32 .25-IN-LG PAN-HD-POZI	28480	2360-0113
	2360-0181	4	SCREW-MACH 6-32 .25-IN-LG 82 DEG	28480	2360-0181
	2360-0330	4	SCREW-MACH 6-32 .188-IN-LG PAN-HD-POZI	28480	2360-0330
	2420-0022	6	NUT-8PCLY 6-32-THD .23-IN-THK .354-OD	28480	2420-0022
	2510-0133	4	SCREW-MACH 6-32 .188-IN-LG PAN-HD-POZI	28480	2510-0133

See introduction to this section for ordering information

Table 6-3. Code List of Manufacturers

MFR NO.	MANUFACTURER NAME	ADDRESS	ZIP CODE
01468	STETTNER-TRUSH INC	CAZENOVIA NY	
01607	ALLEN-BRADLEY CO	MILWAUKEE WI	
01698	TEXAS INSTR INC SEMICOND CMPNT DIV	DALLAS TX	
01921	RCA CORP SOLID STATE DIV	SOMERVILLE NJ	
02037	MOTOROLA SEMICONDUCTOR PRODUCTS	PHOENIX AZ	
02107	VIKING INDUSTRIES INC	CHATSWORTH CA	05574
02172	AIRCO SPEER ELEK DIV AIR RDCN CO	NOGALES AZ	
02180	PRECISION MONOLITHICS INC	SANTA CLARA CA	
02194	ROBINSON NUGENT INC	NEW ALBANY IN	06776
02237	FAIRCHILD SEMICONDUCTOR DIV	MOUNTAIN VIEW CA	
02273	TRW INC BURLINGTON DIV	BURLINGTON IA	
02440	THOMPSON BREMER DIV VARE	CHICAGO IL	06791
02483	CTS OF BERNE INC	BERNE IN	
02608	YHERMALLOY CO	DALLAS TX	
02763	TELEDYNE SEMICONDUCTOR	MOUNTAIN VIEW CA	
02826	DENNISON MFG CO	FRAMINGHAM MA	16956
02883	SILICONIX INC	SANTA CLARA CA	
02910	SIGNETICS CORP	SUNNYVALE CA	
02995	MEPCOELECTRA CORP	MINERAL WELLS TX	
03292	CORNING GLASS WORKS (BRADFORD)	BRADFORD PA	
03316	SPECIALTY CONNECTOR CO INC	INDIANAPOLIS IN	
03406	NATIONAL SEMICONDUCTOR CORP	SANTA CLARA CA	
03418	MOLEX PRODUCTS CO	DOWNERS GROVE IL	27264
03794	ADVANCED MICRO DEVICES INC	SUNNYVALE CA	
03856	MALLORY P R AND CO INC	INDIANAPOLIS IN	37942
04200	SPRAGUE ELECTRIC CO	NORTH ADAMS MA	
04486	ITT CANNON ELECTRIC CO	SANTA ANA CA	71468
04507	TRW ELEK COMPONENTS CINCH DIV	ELK GROVE VLG IL	
04568	BECKMAN INSTRUMENTS INC HELIPOT DIV	FULLERTON CA	73138
04604	FEDERAL SCREW PRODUCTS CO	CHICAGO IL	
04703	LITTELFUSE INC	DES PLAINES IL	
04757	OAK IND INC SW DIV	CRYSTAL LAKE IL	76854
04805	ILLINOIS TOOL WORKS INC SHAKEPROOF	ELGIN IL	78189
05057	SWITCHCRAFT INC	CHICAGO IL	
05683	WECKESSER CO INC	CHICAGO IL	
28440	HEWLETT-PACKARD CO CORPORATE HQ	PALO ALTO CA	94304
75915	LITTELFUSE INC	DES PLAINES IL	60016

SECTION VII MANUAL CHANGES

7-1. INTRODUCTION

7-2. This section normally contains information for adapting this manual to instruments it does not apply to directly. Because this manual does apply directly to all Model 8750A Storage-Normalizers

having the serial numbers listed on the manual's title page, no change information is provided here. For additional information about how instruments with different serial number prefixes are covered, refer to INSTRUMENTS COVERED BY MANUAL in Section I.

SAFETY

This instrument has been designed and tested according to International Safety Requirements. To ensure safe operation and to keep the instrument safe, the information, cautions, and warnings in this manual must be heeded. Refer to Section I for general safety considerations applicable to this instrument.

CERTIFICATION

Hewlett-Packard Company certifies that this instrument met its published specifications at the time of shipment from the factory. Hewlett-Packard Company further certifies that its calibration measurements are traceable to the United States National Bureau of Standards, to the extent allowed by the Bureau's calibration facility, and to the calibration facilities of other International Standards Organization members.

WARRANTY AND ASSISTANCE

This Hewlett-Packard product is warranted against defects in materials and workmanship for a period of one year from the date of shipment. Hewlett-Packard will, at its option, repair or replace products which prove to be defective during the warranty period provided they are returned to Hewlett-Packard, and provided the proper preventive maintenance procedures as listed in this manual are followed. Repairs necessitated by misuse of the product are not covered by this warranty. NO OTHER WARRANTIES ARE EXPRESSED OR IMPLIED, INCLUDING BUT NOT LIMITED TO THE IMPLIED WARRANTIES OF MERCHANTABILITY AND FITNESS FOR A PARTICULAR PURPOSE. HEWLETT-PACKARD IS NOT LIABLE FOR CONSEQUENTIAL DAMAGES.

Service contracts or customer assistance agreements are available for Hewlett-Packard products that require maintenance and repair on-site.

For any assistance, contact your nearest Hewlett-Packard Sales and Service Office. Addresses are provided at the back of this manual.